

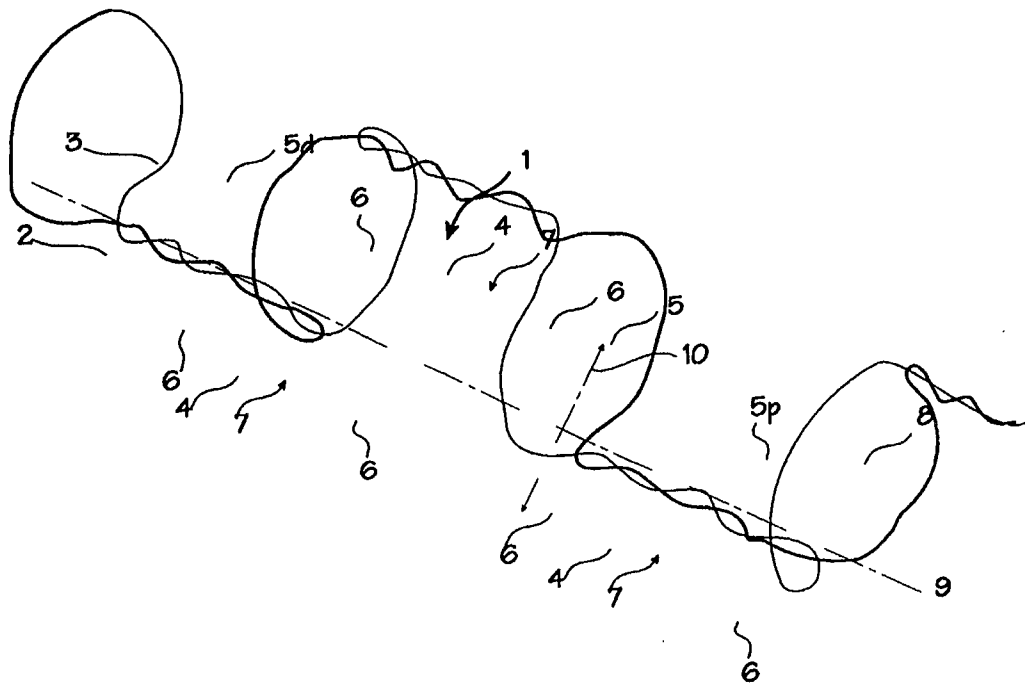

INTERNATIONAL APPLICATION PUBLISHED UNDER THE PATENT COOPERATION TREATY (PCT)

<p>(51) International Patent Classification ⁶ : A61M 29/00</p>	<p>A1</p>	<p>(11) International Publication Number: WO 98/39055 (43) International Publication Date: 11 September 1998 (11.09.98)</p>
<p>(21) International Application Number: PCT/US98/04491 (22) International Filing Date: 6 March 1998 (06.03.98) (30) Priority Data: 08/813,614 7 March 1997 (07.03.97) US (71) Applicant: MICRO THERAPEUTICS, INC. [US/US]; 1062 F Calle Negocio, San Clemente, CA 92672 (US). (72) Inventors: KONYA, Andras; MD Anderson Cancer Center, 1515 Holcombe Boulevard, Houston, TX 77030 (US). WALLACE, Sidney; MD Anderson Cancer Center, 1515 Holcombe Boulevard, Houston, TX 77030 (US). WRIGHT, Kenneth, C.; MD Anderson Cancer Center, 1515 Holcombe Boulevard, Houston, TX 77030 (US). (74) Agent: CROCKETT, K., David; Crockett & Fish, 4093 Tropico Way, Los Angeles, CA 90065 (US).</p>		<p>(81) Designated States: AU, CA, JP, European patent (AT, BE, CH, DE, DK, ES, FI, FR, GB, GR, IE, IT, LU, MC, NL, PT, SE). Published <i>With international search report.</i></p>

(54) Title: HOOP STENT



(57) Abstract
This invention is a stent (1) comprising a single wire (2) fashioned into hoops (5) connected with radially offset struts (7).

FOR THE PURPOSES OF INFORMATION ONLY

Codes used to identify States party to the PCT on the front pages of pamphlets publishing international applications under the PCT.

AL	Albania	ES	Spain	LS	Lesotho	SI	Slovenia
AM	Armenia	FI	Finland	LT	Lithuania	SK	Slovakia
AT	Austria	FR	France	LU	Luxembourg	SN	Senegal
AU	Australia	GA	Gabon	LV	Latvia	SZ	Swaziland
AZ	Azerbaijan	GB	United Kingdom	MC	Monaco	TD	Chad
BA	Bosnia and Herzegovina	GE	Georgia	MD	Republic of Moldova	TG	Togo
BB	Barbados	GH	Ghana	MG	Madagascar	TJ	Tajikistan
BE	Belgium	GN	Guinea	MK	The former Yugoslav Republic of Macedonia	TM	Turkmenistan
BF	Burkina Faso	GR	Greece	ML	Mali	TR	Turkey
BG	Bulgaria	HU	Hungary	MN	Mongolia	TT	Trinidad and Tobago
BJ	Benin	IE	Ireland	MR	Mauritania	UA	Ukraine
BR	Brazil	IL	Israel	MW	Malawi	UG	Uganda
BY	Belarus	IS	Iceland	MX	Mexico	US	United States of America
CA	Canada	IT	Italy	NE	Niger	UZ	Uzbekistan
CF	Central African Republic	JP	Japan	NL	Netherlands	VN	Viet Nam
CG	Congo	KE	Kenya	NO	Norway	YU	Yugoslavia
CH	Switzerland	KG	Kyrgyzstan	NZ	New Zealand	ZW	Zimbabwe
CI	Côte d'Ivoire	KP	Democratic People's Republic of Korea	PL	Poland		
CM	Cameroon	KR	Republic of Korea	PT	Portugal		
CN	China	KZ	Kazakstan	RO	Romania		
CU	Cuba	LC	Saint Lucia	RU	Russian Federation		
CZ	Czech Republic	LI	Liechtenstein	SD	Sudan		
DE	Germany	LK	Sri Lanka	SE	Sweden		
DK	Denmark	LR	Liberia	SG	Singapore		
EE	Estonia						

Hoop Stent

Field of the Invention

This invention relates to stents for use in vascular surgery.

5

Background of the Invention

A wide variety of stent designs have been proposed for use in the vascular system. Typically, the stents are used to hold open a length of blood vessel which has been closed or occluded by some growth within the blood vessel. Balloon expandable stents and self-expanding stents are commercially available and have been used successfully for treatment of a number vascular diseases. Das, Stent, U.S. patent 5,554,181 (Sep. 10, 1996) shows a wire stent having a number of hoops all attached to a radially disposed spine, all of which may be formed of a single wire. Likewise, Hillstead, Endovascular Stent Apparatus and Method, U.S. Patent 4,856,516 (Aug. 15, 1989). The stents are folded upon a catheter pusher and retained within a catheter sheath before release into the body. These stents must be radially compressed to fit within the catheter sheath, and expand elastically or may be expanded inelastically by a balloon. They are not susceptible to being stretched or elongated in the along their long axes to reduce their overall diameter.

Summary

25 The stent and stent delivery system described herein are designed for insertion into blood vessels and other lumens of the body. The self-expandable stent is composed of a single small diameter (0.005 inch) nitinol wire which is doubled first by making a bend at its mid-portion. The wire pair is then led around a tubular jig to form a hoop, and the wires are joined by double twisting or point welding to form a strut, then led

around the tubular jig to form another hoop, joined to form another strut, and so on until the desired number of hoops are formed. The stent may be stretched along the long axis of the stent, whereupon the hoops are deformed into ellipses disposed at an angle approximately midway between the long axis of the stent and the radius of the stent, and the overall diameter of the stent is reduced by this deformation.

To deploy the stent, it is stretched out completely on the surface of a small catheter (3-F). The catheter contains a specially designed angled tip guide wire provided with a low-profile hook. The front end of the constrained stent is hung on the hook. The hook comes out from the catheter's lumen through a hole and goes back into the catheter through another hole. A monofilament retrieving loop runs from the proximal end of the deployment catheter to the proximal end of the stent. The proximal end of the retrieving loop is fastened to a sliding ring attached to the proximal end of the 3-F catheter shaft. Before final release of the stent, the retrieving loop may be operated via the sliding ring to pull the stent in order to correct for any error in the initial placement of the stent. After the stent is properly placed and the retrieving loop may be severed to release the stent from the delivery catheter. The stent has thermal shape memory or pseudoelasticity which facilitates deployment.

Brief Description of The Drawings

Figure 1 is a view of the stent.

Figure 2 is a view of the stent in a stretched condition for loading onto the delivery catheter.

Figure 3 is a cross-section of the delivery catheter for use with the stent.

Figure 4 is a view of the delivery catheter for use with the stent.

Figure 5 is a radial cross-section of the delivery catheter for use with the stent.

Detailed Description of the Invention

Figure 1 shows the stent in its expanded state. The stent
5 1 is comprised of a single wire 2 which is folded at a point
along the wire, such as mid-point 3 to form a length of double
wire comprising two wire segments. Several twisted sections 4
in the double wire are interspersed with several hoops 5 formed
by pulling the double wire apart into the hoop shape. The
10 double wire is then bent at each junction 6 between the twisted
sections and the hoops to form an angle of about 90° between
each hoop and twisted section. The twisted sections 4 create
alternately radially opposed struts or spines 7 between
successive hoops. The free ends 8 of the wire 2 may be twisted
15 into a free spine as shown, or they may be joined together. The
hoops in this arrangement are aligned along a common axis 9 which
defines the longitudinal axis of the stent, and they are
oriented approximately parallel to each other. The stent has an
unconstrained diameter defined by hoop diameter 10. The hoops
20 may be all the same overall diameter, or they may be of
different diameter, and it may be particularly useful to create
the hoops so that the size of the hoops increases from one end
of the stent to the other. The struts may be all the same
length or of varying length. Although shown as being formed by
25 intertwining the two wire segments, the struts maybe formed by
welding the segments together, or by shaping the segments to
run parallel where the strength of the wire permits. Note that
the stent may be formed of two separate lengths of wire, but in
this case a free end strut at distal hoop 5d, or a joint
30 provided elsewhere along the stent, may be required.

Figure 2 shows the stent stretched out in the condition
that it will be loaded onto the delivery catheter. In its
stretched condition, the hoops 5 have elongated into reclining
ellipses 11 oriented at an angle from the longitudinal axis 9 of

the stent 1. The angle is intermediate between the longitudinal axis of the stent and the the radius 12 of the stent. Thus the overall diameter of the stent has been significantly reduced by stretching along the longitudinal axis. The fact that the
5 struts are not radially aligned permits longitudinal stretching or deformation of every hoop in the stent. As illustrated, the each strut is radially opposed to the struts on either side, meaning the each strut is on the opposite side of the stent compared to the preceding or succeeding strut. When the
10 adjacent struts are 180° apart, maximum stretching of the hoops is acheived merely be pulling the ends of the stent. Direct opposition, or opposition of exactly 180°, is not required to obtain the benefit of this construction, and it suffices that the struts not be radially aligned.

15 The stent wires 2 may be made of a shape memory alloy such as nitinol (or other shape memory material), pseudoelastic or superelastic alloy such as nitinol (or other pseudoelastic or superelastic material), spring metal such as stainless steel, or other suitable materials. When made of shape memory nitinol or
20 superelastic nitinol, the stent may be trained to the shape shown in Figure 1, and will revert to that shape either through shape memory behavior at its chosen transition temperature, or through superelastic behavior at body temperature. The appropriate compositions and training regimens may be used to
25 obtain these characteristics. Spring materials such as stainless steel may be used also, and fabricated so that the shape of Figure 1 is the relaxed state of the material which is regained elastically after stretching into the shape shown in Figure 2. As with prior art stents, the stent may also be
30 deployed by inflating a balloon within the stent.

Figure 3 shows a cross-section of the delivery catheter for use with the hoop stent shown in Figures 1 and 2. The delivery catheter 13 is a multi-lumen catheter, preferably with at least two lumens, a guide wire lumen 14 and a retaining loop lumen 15.
35 A guide wire 16 is disposed within the guide wire lumen 14 and a

retaining loop 17 is disposed within the retaining loop lumen 15. The guide wire 16 may be any available guidewire, such as an .012 coronary guidewire, and may have an angled or curved soft tip 18 as shown. The retaining loop loop 17 may be any
5 small diameter wire or thread, made of metal, suture, nylon or other suitable material. The delivery catheter 13 may be made of polyethylene, polyester or any other suitable catheter material, and may be made in convenient length (about 100-135 cm for coronary applications) and diameter (about 3 French (1 mm)
10 for coronary applications).

The guide wire 16 is modified by the addition of a retaining hook 19 attached several centimeters proximal to the distal end of the guidewire, at a location corresponding to the distal end of both the delivery catheter 13 and the stent 1. As
15 shown in Figure 3, the delivery catheter has two retaining hook apertures 20d and 20p. The retaining hook exits the proximal aperture 20p and re-enters the catheter through the distal aperture 20d, and the external portion 21 of the hook traps a section of the stent 1 between the retaining hook and the
20 delivery catheter.

The retaining loop 17 is threaded through the pair of apertures 22p and 22d. The retaining loop 17 enters the retaining loop lumen through the proximal aperture 22p, and exits the lumen through the distal aperture 22d, where it loops
25 around a portion of the wire 2 at the distal end of the stent. The proximal end 23 of the retaining loop is secured to a sliding ring 24 slidably mounted on the delivery catheter proximal end. Figure 5 shows a radial cross-section of the delivery catheter along section a of Figures 3 and 4, with the
30 guidewire 16 inside the guide wire lumen 14 and the retaining loop 17 within the retaining loop lumen 13.

The position of the stent 1 on the delivery catheter 13 is illustrated in Figures 3 and 4. The stent is stretched in order to flatten the hoops. A distal hoop 5d is retained by the

retaining hook 19, while a proximal hoop 5p is retained by the retaining loop 17. Because the stent is stretched between the retaining g loop and the retaining hook, the hoops 5 and spines 7 are pulled taught against the delivery catheter, and the outer diameter of the entire assembly is reduced in comparison to the outer diameter of the expanded stent.

In use, a guiding catheter is used to catheterize the main trunk of the coronary artery (or other blood vessel to be stented). The guiding catheter is inserted percutaneously into the femoral artery and pushed into place near the coronary artery to be stented. The delivery catheter, preferably a 3 F double channel catheter with the completely stretched stent, is advanced into the lumen of the guiding catheter. The catheter-stent unit is advanced into the vessel so that the leading end of the stent can be in the right position. As a first step, the sliding ring is unlocked and moved slowly distally allowing the stent to take on its unconstrained diameter. Using the sliding ring carefully and taking advantage of the thermal memory of the stent, a smooth and controlled deployment can be achieved. At this point, some contrast can be injected via the side port of a check-flow adapter (not shown) which is attached to the guiding catheter. If the deployment is considered unsatisfactory, the retaining loop offers the chance of reposition. By pulling the sliding ring back (proximally) on the catheter, the stent can be stretched completely again. The delivery catheter's position can be changed with manipulation through the retaining loop 17, and the stent can be deployed again. When the deployment is completed, one of the strands of the retaining loop 17 is cut and the retaining loop 17 is pulled out. (Thus the retaining loop serves also as a release/retrieval loop. Note that the retaining loop 17 may be beneficially used without taking advantage of the retrieval function.) Following this maneuver, the guide wire 16 is pulled proximally within the delivery catheter to unhook the stent from the retaining hook. The guide catheter and the delivery catheter 13 are removed together completely.

While the preferred embodiments of the devices and methods have been described in reference to the environment in which they were developed, they are merely illustrative of the principles of the inventions. Other embodiments and
5 configurations may be devised without departing from the spirit of the inventions and the scope of the appended claims.

We claim:

1. A wire frame structure for use within a lumen of the body, said wire frame structure comprising a series of wire hoops longitudinally aligned in generally parallel planes and along a generally common axis through the center of each hoop, wherein successive hoops are joined by struts extending from one wire hoop to the next, and wherein the struts are arranged in radially non-aligned arrangement.
5
2. A wire frame structure for use within a lumen of the body, said wire frame structure comprising a plurality of hoops disposed generally parallel to each other and spaced along an axis defined by the center of the hoops, said hoops being connected by struts between adjacent hoops, wherein each strut connecting a pair of hoops is radially offset from the adjacent struts.
10
15
3. A stent for placement in a lumen of the body, said stent comprising a series of hoops wherein each hoop is connected to adjacent hoops by a strut, wherein the strut connecting one hoop to the next succeeding hoop is radially opposed to the next strut which connects the next succeeding hoop with the second succeeding hoop.
20
4. The stent of claim 3 wherein the stent is comprised of a two segments of wire including first and second segment of wire, said first and second segments of wire having a plurality of opposing semi-circular bends forming hoops, said plurality of opposing semi-circular bends being separated by a generally straight section in each of the first and second segments of wire forming a strut, said first and second segments of being bent near each junction between a hoop and a strut so that the planar centers of the hoops are aligned along a common axis.
25
30
5. The stent of claim 4 wherein the two segments of wire are part of a single length of wire folded to form two segments of wire.

6. The stent of claim 4 wherein the struts are formed by intertwining the generally straight sections of the first and second segments of wire.

7. A stent and stent delivery system comprising:

5 a stent comprising a plurality of hoops connected by struts;

10 said stent being mounted upon an insertion catheter tube having at least one lumen within the tube, said insertion catheter tube having at a retaining clip side aperture near the distal end of the stent and at a retaining loop side aperture near the proximal end of the stent;

15 a retaining loop extending from the proximal end of the insertion catheter tube, through a lumen in the insertion catheter tube and out the retaining loop side aperture and engaging the stent to secure it to the insertion catheter tube;

20 a retaining clip extending from a lumen in the insertion catheter tube and out the retaining clip side aperture and engaging the stent to secure it to the insertion catheter tube;

25 said retaining clip being operably connected to a wire in the lumen of the insertion catheter tube, where said wire extends to the proximal end of the insertion catheter and is operable to withdraw the retaining clip from engagement with the stent;

said retaining loop being severable to release the stent from retention by the retaining loop.

8. The stent and stent delivery system of claim 7, wherein:

the stent is characterized by an unconstrained diameter and a longitudinally stretched diameter, and the stretched diameter is smaller than the unconstrained diameter, and

5 the stent is mounted on the insertion catheter tube in the stretched condition having the smaller stretched diameter and secured to the insertion catheter tube by the retaining loop and retaining clip; and

10 the stent may be released from the insertion catheter by withdrawing the retaining clip from engagement with the stent and severing the retaining loop to release the stent from retention by the retaining loop, whereupon the stent may expand to its unconstrained diameter.

9. The stent of claim 7, wherein the stent is comprised of a shape memory material.

15 10. The stent of claim 7, wherein the stent is comprised of a pseudoelastic material.

11. The stent of claim 7, wherein the stent is comprised of a shape memory nitinol.

20 12. The stent of claim 7, wherein the stent is comprised of a pseudoelastic nitinol.

13. The stent of claim 3, wherein the stent is comprised of a shape memory material.

14. The stent of claim 3, wherein the stent is comprised of a pseudoelastic material.

25 15. The stent of claim 3, wherein the stent is comprised of a shape memory nitinol.

16. The stent of claim 3, wherein the stent is comprised of a pseudoelastic nitinol.

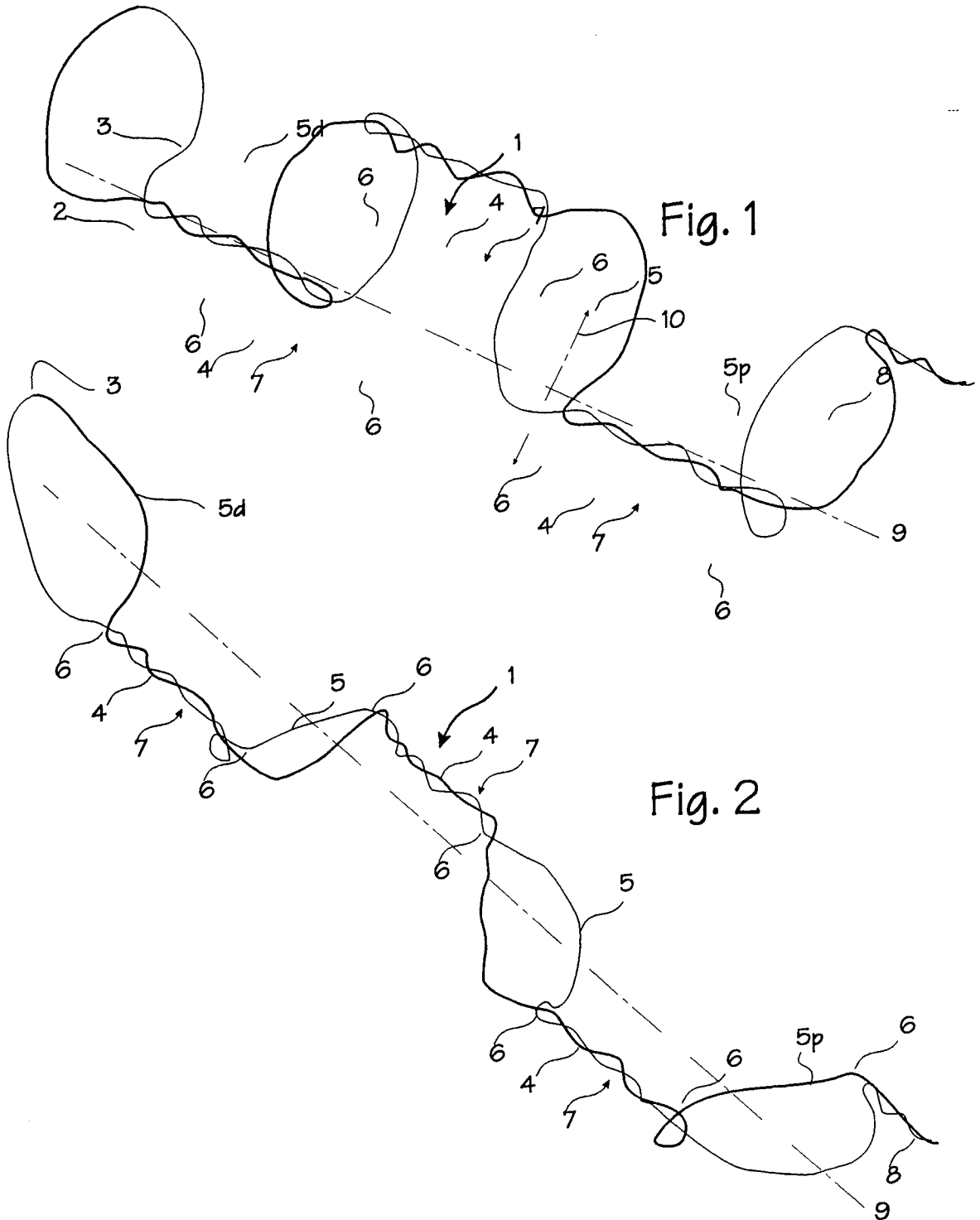

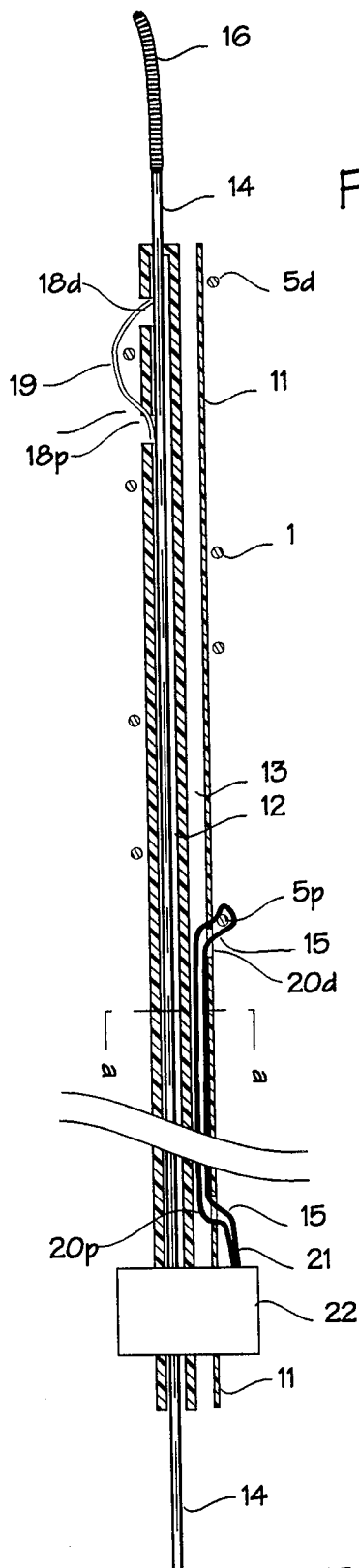

Fig. 3

Fig. 4

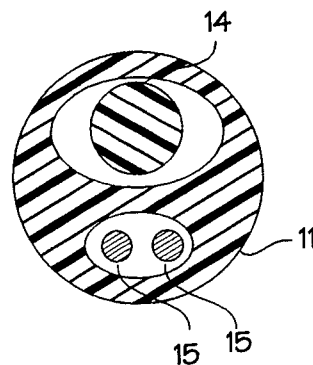
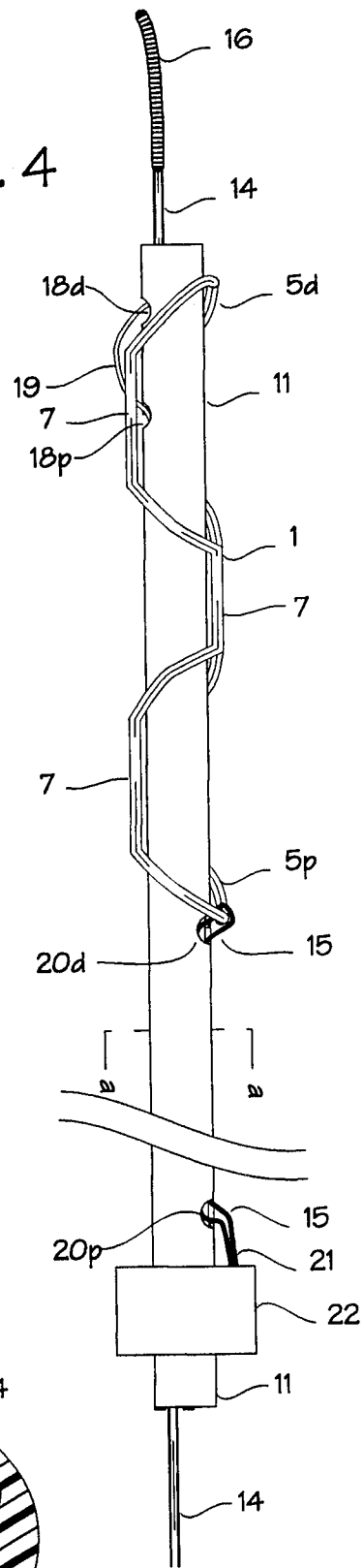

Fig. 5

INTERNATIONAL SEARCH REPORT

International application No.
PCT/US98/04491

A. CLASSIFICATION OF SUBJECT MATTER
 IPC(6) :A61M 29/00
 US CL :606/108, 192, 194, 198
 According to International Patent Classification (IPC) or to both national classification and IPC

B. FIELDS SEARCHED
 Minimum documentation searched (classification system followed by classification symbols)
 U.S. : 606/108, 192, 194, 198

Documentation searched other than minimum documentation to the extent that such documents are included in the fields searched
 NONE

Electronic data base consulted during the international search (name of data base and, where practicable, search terms used)
 NONE

C. DOCUMENTS CONSIDERED TO BE RELEVANT

Category*	Citation of document, with indication, where appropriate, of the relevant passages	Relevant to claim No.
X	US 4,913,141 A (HILLSTEAD) 03 April 1990, Figs. 3 and 4.	7, 8
---		-----
Y		1-6, 9-16
A	US 5,554,181 A (DAS) 10 September 1996, entire document.	1-16

Further documents are listed in the continuation of Box C. See patent family annex.

- | | |
|---|--|
| * Special categories of cited documents: | *T* later document published after the international filing date or priority date and not in conflict with the application but cited to understand the principle or theory underlying the invention |
| *A* document defining the general state of the art which is not considered to be of particular relevance | *X* document of particular relevance; the claimed invention cannot be considered novel or cannot be considered to involve an inventive step when the document is taken alone |
| *B* earlier document published on or after the international filing date | *Y* document of particular relevance; the claimed invention cannot be considered to involve an inventive step when the document is combined with one or more other such documents, such combination being obvious to a person skilled in the art |
| *L* document which may throw doubts on priority claim(s) or which is cited to establish the publication date of another citation or other special reason (as specified) | *A* document member of the same patent family |
| *O* document referring to an oral disclosure, use, exhibition or other means | |
| *P* document published prior to the international filing date but later than the priority date claimed | |

Date of the actual completion of the international search 23 APRIL 1998	Date of mailing of the international search report 19 MAY 1998
--	---

Name and mailing address of the ISA/US Commissioner of Patents and Trademarks Box PCT Washington, D.C. 20231 Facsimile No. (703) 305-3230	Authorized officer <i>Kevin Truong</i> KEVIN TRUONG Telephone No. (703) 308-3767
---	---