



INTERNATIONAL APPLICATION PUBLISHED UNDER THE PATENT COOPERATION TREATY (PCT)

<p>(51) International Patent Classification ⁷ : A61B 17/22</p>	<p>A1</p>	<p>(11) International Publication Number: WO 00/51505 (43) International Publication Date: 8 September 2000 (08.09.00)</p>
<p>(21) International Application Number: PCT/US00/05441 (22) International Filing Date: 3 March 2000 (03.03.00) (30) Priority Data: 09/262,994 5 March 1999 (05.03.99) US (63) Related by Continuation (CON) or Continuation-in-Part (CIP) to Earlier Application US 09/262,994 (CON) Filed on 5 March 1999 (05.03.99) (71) Applicant (for all designated States except US): BOARD OF REGENTS, THE UNIVERSITY OF TEXAS SYSTEM [US/US]; 201 W. 7th Street, Austin, TX 78701 (US). (72) Inventors; and (75) Inventors/Applicants (for US only): KONYA, Andras [HU/US]; Apt. 256, 550 North Braeswood, Houston, TX 77096 (US). WRIGHT, Kenneth, C. [US/US]; 1802 Haver, Houston, TX 77006 (US). (74) Agent: GARRETT, Mark, T.; Fulbright & Jaworski L.L.P., Suite 2400, 600 Congress Avenue, Austin, TX 78701 (US).</p>		<p>(81) Designated States: AE, AL, AM, AT, AU, AZ, BA, BB, BG, BR, BY, CA, CH, CN, CR, CU, CZ, DE, DK, DM, EE, ES, FI, GB, GD, GE, GH, GM, HR, HU, ID, IL, IN, IS, JP, KE, KG, KP, KR, KZ, LC, LK, LR, LS, LT, LU, LV, MA, MD, MG, MK, MN, MW, MX, NO, NZ, PL, PT, RO, RU, SD, SE, SG, SI, SK, SL, TJ, TM, TR, TT, TZ, UA, UG, US, UZ, VN, YU, ZA, ZW, ARIPO patent (GH, GM, KE, LS, MW, SD, SL, SZ, TZ, UG, ZW), Eurasian patent (AM, AZ, BY, KG, KZ, MD, RU, TJ, TM), European patent (AT, BE, CH, CY, DE, DK, ES, FI, FR, GB, GR, IE, IT, LU, MC, NL, PT, SE), OAPI patent (BF, BJ, CF, CG, CI, CM, GA, GN, GW, ML, MR, NE, SN, TD, TG).</p> <p>Published <i>With international search report. Before the expiration of the time limit for amending the claims and to be republished in the event of the receipt of amendments.</i></p>
<p>(54) Title: A DECLOTTING METHOD AND APPARATUS</p>		
<p>(57) Abstract</p> <p>A declotting apparatus includes a catheter, a member positioned within the catheter, and a plurality of deformable members. The plurality of members bow and compress as the catheter slides relative to the member so that a site may be declotted. In another embodiment, a declotting apparatus includes a first and second catheter, a guidewire, a deformable jacket, and a liner. The deformable jacket expands and contract as the first catheter slides relative to the second catheter so that a site may be declotted. The guidewire facilitates navigation, and the liner prevents material from entering the apparatus.</p> <div data-bbox="1161 1220 1444 2116" data-label="Image"> </div>		

FOR THE PURPOSES OF INFORMATION ONLY

Codes used to identify States party to the PCT on the front pages of pamphlets publishing international applications under the PCT.

AL	Albania	ES	Spain	LS	Lesotho	SI	Slovenia
AM	Armenia	FI	Finland	LT	Lithuania	SK	Slovakia
AT	Austria	FR	France	LU	Luxembourg	SN	Senegal
AU	Australia	GA	Gabon	LV	Latvia	SZ	Swaziland
AZ	Azerbaijan	GB	United Kingdom	MC	Monaco	TD	Chad
BA	Bosnia and Herzegovina	GE	Georgia	MD	Republic of Moldova	TG	Togo
BB	Barbados	GH	Ghana	MG	Madagascar	TJ	Tajikistan
BE	Belgium	GN	Guinea	MK	The former Yugoslav Republic of Macedonia	TM	Turkmenistan
BF	Burkina Faso	GR	Greece			TR	Turkey
BG	Bulgaria	HU	Hungary	ML	Mali	TT	Trinidad and Tobago
BJ	Benin	IE	Ireland	MN	Mongolia	UA	Ukraine
BR	Brazil	IL	Israel	MR	Mauritania	UG	Uganda
BY	Belarus	IS	Iceland	MW	Malawi	US	United States of America
CA	Canada	IT	Italy	MX	Mexico	UZ	Uzbekistan
CF	Central African Republic	JP	Japan	NE	Niger	VN	Viet Nam
CG	Congo	KE	Kenya	NL	Netherlands	YU	Yugoslavia
CH	Switzerland	KG	Kyrgyzstan	NO	Norway	ZW	Zimbabwe
CI	Côte d'Ivoire	KP	Democratic People's Republic of Korea	NZ	New Zealand		
CM	Cameroon			PL	Poland		
CN	China	KR	Republic of Korea	PT	Portugal		
CU	Cuba	KZ	Kazakstan	RO	Romania		
CZ	Czech Republic	LC	Saint Lucia	RU	Russian Federation		
DE	Germany	LI	Liechtenstein	SD	Sudan		
DK	Denmark	LK	Sri Lanka	SE	Sweden		
EE	Estonia	LR	Liberia	SG	Singapore		

DESCRIPTION

A DECLETTING METHOD AND APPARATUS

BACKGROUND OF THE INVENTION

5 **1. Field of the Invention**

The present invention relates generally to the field of interventional radiology. More particularly, it concerns a method and apparatus for reconstruction a flow path within a vascular conduit , and even more particularly, it concerns embolectomy and thrombectomy including treatment of thrombosed hemodialysis access grafts.

10

2. Description of Related Art

More than 129,000 patients are undergoing hemodialysis in the U.S. (Gray, 1997), and the leading cause for hospital admission is a problem related to life-sustaining access (Feldman, 1993). More than 80% of this patient population have a PTFE graft access which provides an average patency of 20 months after placement (Gray, 1997).

15

If one considers that the arterial and venous anatomy is typically sufficient to support three upper extremity grafts, a dialysis patient may expect an average 10 years (20 months times six grafts) of permanent access availability from upper extremities (Gray, 1997). Depending on the age when the kidneys fail, between 23 and 51% of patients will live at least 10 additional years after starting dialysis (Mailloux, 1994). If a renal transplant does not become available, many patients will need to resort to peritoneal dialysis or a less preferable hemodialysis access such as a lower extremity graft or a hemodialysis catheter. Some patients may even die because of lack of access. Therefore, efforts to maintain each available permanent hemodialysis access have become a matter of paramount importance.

20

25

There are at least three primary interventional radiology methods for percutaneous thrombolysis: urokinase infusion, pulse-spray pharmacomechanical

30

thrombolysis with urokinase, and pure mechanical thrombolysis (Bethard, 1996; Trerotola, 1994; Beathard, 1994; Trerotola, 1997). The pharmacomechanical thrombolysis is often expensive because it may require a min. 350,000 and up to 1,200,000 U urokinase (approximately \$100 / 100,000 U. The pulse-spray
5 heparinized saline technique (Beathard, 1994), however, has proved as effective as the pulse-spray urokinase infusion in terms of long-term patency rates. The only statistically significant difference was that a without-urokinase-group took somewhat less time to complete. Recently, it has been found that the added urokinase reduced the rate of clinically asymptomatic pulmonary embolism (detected nuclear medicine
10 perfusion scan) , and the complications were more frequent with heparinized saline method (Kinney *et al.*, 1999).

Several devices have been used to perform mechanical thrombolysis. A rotating nitinol basket-like fragmentation cage (Arrow-Trerotola Percutaneous
15 Trombolytic Device) has been used by crossing 5-F sheaths within a graft and requires only a minute or two to restore flow. In a recent study, fifty-one consecutive patients were treated with the device. In all patients, the device was used to treat also the arterial plug *in situ* at the arterial anastomosis instead of using a Fogarty catheter to reposition the plug as indicated by the device's product labeling. Immediate
20 technical patency was 100% with 6% arterial immobilization (vs 2% control). Adjunctive therapy with an Fogarty Adherent Clot catheter was needed in two procedures (4%). This modified method was found to be safe and effective when the device was used to eliminate the need for an Fogarty embolectomy catheter . (Modified use of the Arrow-Trerotola, 1999). The device costs cca. \$500.

25

The Amplatz mechanical thrombectomy device (Clot Buster) (Microvena Co., has also been used successfully in dialysis grafts (Uflacker, 1996). This 8-F device consists of a gas-driven, high-speed (150,000 rpm) cam that pulverizes the clot. In a randomized series comparing surgical thrombectomy with the device, 89% success
30 was achieved in the device group and 83% in the surgery group. Thirty-day patency was lower with the device (47%) than with surgery (77%). However, residual

thrombus may occur with the device, and it cannot be used to treat the arterial plug. Recently the device has been made available also in a 6-French version. The cost of the disposable catheter is \$550 and \$900 (6-French/75-cm or 8-French/50-cm and 6-French/120-cm or 8-French/120-cm, respectively). The re-usable foot pedal assembly costs additionally. Because the device is not guidewire compatible, a 6-French ID or 8-French ID delivery sheath or a 8-French OD or 6-French OD guiding catheter should be used.

The Hydrolyser catheter (Cordis) uses the Venturi effect to achieve mechanical thrombolysis . The catheter is driven using a conventional angiographic injector. Although thrombectomy was successful in 15/16 instances, five reclotted within 24 h. Secondary patency was 41% at 6 months (Vorwerk, 1994). One concern with this device, however, is the amount of blood aspirated during the procedure (50-150 mL) which could be problematic for these chronically anemic patients. This device is expected to cost \$600.

The Cragg thrombolytic brush consisting of a 6-French brush catheter combines mechanical thrombolysis with urokinase to shorten procedure time and reduce urokinase dose. It is not a purely mechanical thrombolytic approach, but it takes advantage of many principles of mechanical thrombolysis. This 6-F device consists of a nylon brush that rotates at low speed (1,800 rpm.) driven by a single-use detachable motor drive. It is not guidewire compatible. It costs \$595. Another similar design is the Castaneda Over-the Wire Brush (MTI) which is more preferred because of its guidewire compatibility. The brush itself is modified and allows for using the system forward and backward. The cost is also \$595.

U.S. Patent No. 4,921,484, incorporated herein by reference, discloses a device that uses a tubular mesh in a mesh balloon catheter device. Although this design has shown some utility, it does not offer guidewire compatibility. Thus, it may be necessary to use an additional device(s) to steer towards a desired place within a vessel.

Among simpler devices, the Fogarty Arterial Embolectomy Catheter (Baxter Scientific Products, McGaw Park, IL) (\$45) has shown some utility in removing arterial clots. Although original Fogarty catheters were not guidewire compatible, 5 guidewire compatible Fogarty balloons (Baxter) (\$72) have recently been made available. Other over-the-wire alternatives include occlusion balloons (\$110), and PTA balloons (\$160-220) to macerate the clots. The basic technique for recanalization of hemodialysis access graft using these devices often consists of a cross-over catheterization requiring, unfortunately, multiple equipment. Specifically, 10 two introducer sheaths and two balloon catheters are used. For dislodgment of an arterial plug or intragraft stenosis, the Fogarty Adherent Clot Catheter (Baxter) (\$195) has been successfully used in some cases (Trerotola, 1995). Another similar alternative is the Fogarty Graft Thrombectomy Catheter (Baxter) (\$325), which was designed to remove tough, mature thrombus from synthetic grafts. Except for the 15 over-the wire Fogarty balloon, the other designs have no guidewire compatibility.

Despite many advantages, traditional mechanical thrombolytic devices often exhibit significant drawbacks. Some devices are large (8F or more) and perform poorly in curved vessels, limiting their use in hemodialysis access. Residual adherent 20 clot is a considerable problem with some of mechanical devices. Many devices do not remove the macerated clot and it may be embolized into the lungs. A great number of the available devices cannot be used over-the-wire.

The long term success rates of these methods are generally comparable to 25 those of surgery which should be reserved for failures of percutaneous thrombolysis. Even successful intervention, however, does not eliminate the precipitating factors which cause intragraft thrombosis to occur. Recurrent thrombosis requires further interventions to be made on a regular basis until the dialysis access can be saved. On average, 0.5 to 0.8 episodes of access site thrombosis occur per patient-year of 30 dialysis (Kumpe, 1997). Stenosis at or near the venous anastomosis is the most

common cause of late access thrombosis. The endoluminal narrowing can be identified as the cause in cases up to 90% (Beathard, 1994).

5 Any problems pointed out in the foregoing are not intended to be exhaustive but rather are among many that tend to impair the effectiveness of previously known techniques. Other noteworthy problems may also exist; however, those presented above should be sufficient to demonstrate that previous techniques appearing in the art have not been altogether satisfactory, particularly in providing a rapid, effective, safe, easily performed, and minimally invasive outpatient procedure that will restore
10 function to a thrombosed graft or vessel.

SUMMARY OF THE INVENTION

15 In one aspect, the invention is a declotting apparatus including a catheter, a member, and a plurality of deformable members. The member is positioned within the catheter and is slidable relative to the catheter. The plurality of deformable members form at least one loop and have a proximal portion and a distal portion. The proximal portion is coupled to the catheter at a proximal site, and the distal portion is coupled to the member at a distal site. The proximal site and the distal site are
20 separated by a distance. The plurality of deformable members are configured to bow as the catheter slides to reduce the distance. The plurality of deformable members are configured to compress as the catheter slides to increase the distance.

25 In other aspects, the plurality of deformable members may form at least two loops. The plurality of deformable members may be programmed with thermal memory. The plurality of deformable members may be programmed with superelasticity. The plurality of deformable members may include nitinol wire. The plurality of deformable members may be elastically deformable. The declotting apparatus may also include a deformable jacket in operable relation to the plurality of
30 deformable members. The jacket may be configured to cover at least a portion of the plurality of deformable members. The deformable jacket may be configured to

expand as the plurality of deformable members bow, and the deformable jacket may be configured to contract as the plurality of deformable members compress. The deformable jacket may include braided stainless steel mesh. The declotting apparatus may also include a liner coupled to an inner surface of the deformable jacket. The
5 liner may be configured to prevent material from entering an interior of the declotting apparatus. The declotting apparatus may also include a pair of clips coupled to the plurality of deformable members. The declotting apparatus may also include a sliding agent in operative relation to the catheter and the member and may be operable to slide the catheter relative to the member. The sliding agent may include a hand grip, a
10 one-arm lever coupled to the hand grip and to the catheter, a luer adaptor coupled to the member, and a spring coupled to the hand grip and to the one-arm lever, with the spring extending therebetween. The sliding agent may include a grip body, a luer adaptor coupled to the grip body, a spring coupled to the grip body and configured to pull the catheter to compress the deformable members, a thumb button coupled to the
15 spring and the catheter and configured to control the extent of compression of the deformable members, and ; a ratchet mechanism in operative relation to the thumb button and configured to engage the thumb button to lock a position of the deformable members. The declotting apparatus may also include a lock in operative relation to the catheter and the member. The lock may be configured to fix the distance between
20 the proximal site and the distal site. The declotting apparatus may also include an injection port and one or more injectors coupled to the catheter. The member may include a catheter. The declotting apparatus may also include a guidewire positioned within the catheter and extending through the distal site. The guidewire may be angled. The member may include a nitinol microtubing. The member may include a
25 nitinol wire.

In another aspect, the invention is a declotting apparatus including a first catheter, a second catheter, a deformable jacket, a guidewire, and a liner. The first catheter defines a first lumen, and the second catheter defines a second lumen. The
30 second catheter is positioned within the first lumen and is slidable relative to the first catheter. The deformable jacket has a proximal end and a distal end. The proximal

end is coupled to the first catheter at a proximal site, and the distal end is coupled to the second catheter at a distal site. The guidewire is positioned within the second catheter and extends through the distal site. The liner is coupled to an inner surface of the deformable jacket and is configured to prevent material from entering an interior of the apparatus. The proximal site and the distal site are separated by a distance. The deformable jacket is configured to expand as the first catheter slides to reduce the distance. The deformable jacket is configured to contract as the first catheter slides to increase the distance.

10 In other aspects, the declotting apparatus may also include a plurality of deformable members coupled between the proximal site and the distal site. The plurality of deformable members may form at least one loop. The plurality of deformable members may be programmed with thermal memory. The plurality of deformable members may be programmed with superelasticity. The plurality of deformable members may include nitinol wire. The declotting apparatus may also include a pair of clips coupled to the plurality of deformable members. The deformable jacket may include a braided stainless steel mesh. The declotting apparatus may also include a lock in operative relation to the first and second catheters and may be configured to fix the distance between the proximal site and the distal site. The declotting apparatus may also include a sliding agent in operative relation to the first and second catheters and operable to slide the first catheter relative to the second catheter. The declotting apparatus may also include an injection port and one or more injectors coupled to the first catheter. The second catheter may include a nitinol microtubing.

25

In another aspect, the invention is a method for declotting a site. A declotter including a catheter; a member positioned within the catheter; a plurality of deformable members forming at least one loop, the members having a proximal portion and a distal portion, the proximal portion being coupled to the catheter at a proximal site and the distal portion being coupled to the member at a distal site; the proximal site and the distal site being separated by a distance; and a deformable jacket

30

in operable relation to the plurality of deformable members is provided. The plurality of deformable members are compressed by sliding the catheter relative to the member to increase the distance and to contract the deformable jacket. The declotter is positioned adjacent the site. The plurality of deformable members are bowed by sliding the catheter relative to the member to decrease the distance and to expand the deformable jacket to declot the site.

In other aspects, the method may also include locking the deformable jacket in a contracted state. The method may also include continuously modifying a diameter of the deformable jacket by sliding the catheter relative to the member. The declotter may also include an injection port and one or more injectors coupled to the catheter, and the method may also include injecting contrast through the declotter with the injection port. The site may be an thrombosed hemodialysis access graft site. The site may be a thrombosed intragraft site. The site may be a venous stenosis site.

In another aspect, the invention is a method for declotting a site. A declotter including a first catheter defining a first lumen; a second catheter defining a second lumen, the second catheter positioned within the first lumen; a guidewire positioned within the second catheter; a deformable jacket having a proximal end and distal end, the proximal end being coupled to the first catheter at a proximal site and the distal end being coupled to the second catheter at a distal site; wherein the proximal site and the distal site are separated by a distance; and a liner coupled to an inner surface of the deformable jacket is provided. The deformable jacket is contracted by sliding the first catheter relative to the second catheter to increase the distance. The declotter is maneuvered with the guidewire. The declotter is positioned adjacent the site. The deformable jacket is expanded by sliding the first catheter relative to the second catheter to decrease the distance to declot the site.

In other aspects, the method may also include preventing material from entering an interior of the declotter with the liner. The method may also include continuously modifying a diameter of the deformable jacket by sliding the first

FIG. 7 shows a declotting apparatus including a sliding agent and injection port according to one embodiment of the presently disclosed method and apparatus.

5 FIG. 8 shows a sliding agent according to one embodiment of the presently disclosed method and apparatus.

FIG. 9A shows another sliding agent according to one embodiment of the presently disclosed method and apparatus.

10 FIG. 9B shows a top view of another sliding agent according to one embodiment of the presently disclosed method and apparatus.

15 FIG. 10 shows a declotting apparatus being used to recanalize a hemodialysis access graft sight according to one embodiment of the presently disclosed method and apparatus.

DESCRIPTION OF ILLUSTRATIVE EMBODIMENTS

20 It will be appreciated that the presently disclosed methods and apparatus provide for certain significant advantages. For instance, the methods and apparatus allow for effective general declotting application, clot maceration, removal of an arterial plug, and the reduction or elimination of intragraft thrombosis(es). Because it may be flexible, the apparatus may be used with any suitable access shaft. A single
25 apparatus may be used for cross-catheterization procedures so the number of devices needed to perform declotting may be advantageously reduced, which also reduces costs. Due to the continuously changeable diameter of the apparatus, optimal wall contact between the apparatus and a wall of, for instance, a graft may be achieved during manipulation. Its compact design, in one embodiment, provides controllable
30 resistance and lets an operator better feel the apparatus during a given procedure. Due, in part, to its low profile, the apparatus does not require large access sheaths,

although large access sheaths may be used if desired. Further, in one embodiment, the apparatus may be used with a suitable guidewire to facilitate maneuverability during a procedure. Its relatively simple design provides an inexpensive method and apparatus for declotting applications. In one embodiment, the apparatus advantageously allows
5 for an injection port to inject, for example, contrast, heparin, or urokinase during a procedure.

Turning first to FIG. 1, there is shown a declotting apparatus **10** according to one embodiment of the presently disclosed method and apparatus. Apparatus **10**
10 includes a catheter **12**, a member **14**, and a deformable jacket **16**. Jacket **16** has a proximal end **18** and a distal end **20**. The proximal end is coupled to catheter **12** at proximal site **22**. Distal end **20** is coupled to member **14** at distal site **24**. As illustrated, proximal site **22** and distal site **24** may be separated by a distance. In operation, the distance between proximal site **22** and distal site **24** may be changed by
15 sliding catheter **12** relative to member **14** so that deformable jacket **16** becomes expanded or contracted. It is to be understood that in other embodiments, member **14** may be moved relative to catheter **12** so as to achieve a similar effect upon deformable jacket **16**. The expansion of deformable jacket **16** allows for the maceration of clots and for the declotting of a site, including, but not limited to a vascular stenosis, or a
20 thrombosed hemodialysis polytetrafluoroethylene (PTFE) graft site.

With reference to FIG. 1, FIG. 2 and FIG. 3, it may be seen how declotting apparatus **10** may be continuously expanded or contracted. With proximal end **18** being coupled to catheter **12** and distal end **20** being coupled to member **14**, sliding
25 catheter **12** relative to member **14** correspondingly changes the distance between proximal site **22** and distal site **24**. That change in distance leads to a deformation of jacket **16** so that deformable jacket **16** expands or contracts. Declotting apparatus **10** may have a working profile that can be continuously changed and that can generate an expansile force for dilation. In FIG. 1, the distance between proximal site **22** and
30 distal site **24** may be seen to be at or near a maximum value. In this configuration, declotting apparatus **10** may be said to be in a fully contracted state. In such a low-

profile state, declotting apparatus 10 may be inserted through an appropriate access catheter or sheath and may be negotiated through, for instance, a hemodialysis graft.

5 In FIG. 2, it may be seen that the distance between proximal site 22 and distal site 24 is less than that shown in FIG. 1. In this state, it may be said that declotting apparatus 10 is in a semi-expanded state. As illustrated, as the distance between proximal site 22 and distal site 24 is reduced, deformable jacket 16 may be seen to expand, taking on a bowed or arcuate shape. Such an arcuate shape may allow for, for instance, the maceration of one or more clots. In FIG. 3, it may be seen that the distance between proximal site 22 and distal site 24 is less than that shown in FIG. 1 and FIG. 2. In such a configuration, it may be said that declotting apparatus 10 is in a fully expanded state. By fully expanded, it is meant that the distance between proximal site 22 and distal site 24 cannot be made shorter. As seen in FIG. 3, the distance may not be made shorter because catheter 12 may not slide more because distal site 24 blocks any further motion. In simpler terms, deformable jacket 16 cannot be further expanded because catheter 12 runs into distal site 24 so that further expansion of deformable jacket 16 may not occur. The degree to which deformable jacket 16 may be maximally expanded may be adjusted by setting the distance between the distal end of catheter 12 (*i.e.* the end closest to distal site 24) and distal site 24. In one embodiment, the distal end of catheter 12 may be about 25 mm from distal site 24.

Catheter 12 may be constructed of any suitable material of any suitable size, but in one embodiment, it may be constructed from Teflon, and it may have a diameter of about 4-F to 5-F. In one embodiment, the Teflon material ensures a smooth sliding movement relative to member 14. Catheter 12 may define a lumen in its interior to accommodate member 14. In one embodiment, member 14 may be a nitinol wire having a length of about 35 cm and a diameter of about 0.017-0.019-inches. However, with the benefit of the present disclosure, those having skill in the art will recognize that member 14 may be constructed of any suitable material and its size may vary according to need. In one embodiment, member 14 may itself be a

catheter. In such an embodiment, member **14** may be constructed from any suitable material such as, but not limited to, Teflon, Nylon, or any suitable (firm but still flexible) plastic material. In one embodiment, member **14** may be a Teflon catheter have a diameter of about 2.5-French to about 3.5-French. In another embodiment, member **14** may be a superelastic Nitinol microtubing capable of accepting a guidewire of about 0.018-inches to about 0.0035-inches. In such an embodiment, the outer diameter of the Nitinol microtubing may be selected accordingly, from an OD of about 0.025-inches to about 0.040-inches. Those having skill in the art will recognize, however, that other relative sizes may be substituted therewith according to need.

10

As illustrated in FIG. 1, FIG. 2, FIG. 3 and FIG. 7, member **14** may extend beyond a distal site to define a guide **26**. In one embodiment, guide **26** may be curved, angled, or otherwise may to conform to a suitable shape to facilitate, for example, the guidance of declotting apparatus **10** within an enclosure within a patient. Although here illustrated as being defined by member **14**, it is contemplated that guide **26** may be distinct from member **14**. In such an embodiment, guide **26** may be constructed from a material different than that of member **14**. For example, guide **26** may be constructed from any suitable material including, but not limited to, stainless steel, nitinol, tungsten, or any combination of thereof. In one embodiment, guide **26** is composed of an inner core (stainless steel, nitinol) which is wrapped around a coil (stainless steel, tungsten). In embodiments where guide **26** is a distinct member, coupling to declotting apparatus **10** may be accomplished by any suitable manner known in the art. For example, guide **26** may be coupled to declotting apparatus **10** by tying, welding, gluing, clipping, fastening, crimping, or any combination thereof.

20
25

In one embodiment, proximal site **22** may be defined by any suitable coupling technique known in the art. For example, deformable jacket **16** may be coupled to catheter **12** at proximal site **22** by tying, crimping, fastening, gluing, welding, or any combination thereof. In embodiments where tying defines proximal site **22**, the tying may be done with mono filament line such as Prolene 5-0, 6-0, 7-0 (polypropylene suture, Ethicon). Likewise, distal site **24** may be defined by any coupling technique

30

well known in the art. For example, distal site **24** may be characterized by tying, crimping, fastening gluing, welding, or any combination thereof.

In one embodiment, deformable jacket **16** may be made from a braided mesh stainless steel. However, with the benefit of the present disclosure, those having skill
5 in the art will recognize that many different suitable materials may be substituted therewith. For instance, in other embodiments, the deformable jacket **16** may be constructed from nitinol, or suitable plastic materials (*e.g.*, nylon) In one embodiment, deformable jacket **16** may be meshed to facilitate the maceration of
10 clots. In one embodiment, the relative rough outer surface of the braided stainless steel mesh makes the apparatus especially suitable for clot maceration and hemodialysis graft applications.

As deformable jacket **16** is maneuvered within a cavity, deformable jacket **16**
15 may intercept portions of a clot and macerate that clot in the space between its meshed outer surface. The size and shape of deformable jacket **16** may vary widely according to need, but in one embodiment, deformable jacket **16** may extend to a diameter of about 6 mm and may form a fusiform shape when it is in a relaxed state. In one embodiment, the spacing of meshed material may be about 1-mm.

20 In one embodiment, deformable jacket **16** may include an inner liner **17** (FIG. 2). Such a liner may be useful to prevent any material, such as blood clots, from accumulating within the body of declotting apparatus **10**. In one embodiment, inner liner **17** may be constructed from an ultra-thin (*i.e.* about 0.02-mm) polyurethane
25 cover, but it is to be understood that any other suitable material and thickness may be substituted therewith. Liner **17** may be coupled to deformable jacket **16** by any suitable manner known in the art, but in one embodiment coupling may be accomplished by gluing, or heating.

30 Turning now to FIG. 4, there is shown a declotting apparatus **10** that includes a catheter **12**, a member **14**, a plurality of deformable members **30**, a proximal portion

22, a distal portion 24, a guidewire 15 having an angled portion 17, and a pair of clips 32. The operation of the embodiment illustrated in FIG. 4 is similar to that of the embodiments illustrated in FIG. 1, FIG. 2 and FIG. 3 in that the distance between proximal portion 22 and distal portion 24 may be modified so as to expand or contract the plurality of deformable members 30. More particularly, the distance may be modified to bow the plurality of deformable members 30 as the distance is reduced, and to compress the plurality of deformable members 30 as the distance is increased. The distance between proximal portion 22 and distal portion 24 may be changed by sliding catheter 12 relative to member 14 (or vice versa).

In one embodiment, catheter 12 may be a Teflon catheter having a diameter of about 4-F to 5-F, but it is to be understood that any other suitable material and size may be substituted therewith. Likewise, it will be understood by those having skill in the art any other suitable structure defining an interior lumen may be substituted for catheter 12. In one embodiment, member 14 may be a nitinol wire or other suitable structure. In the illustrated embodiment, member 14 is a catheter that defines an interior lumen. In one embodiment, member 14 may be a Teflon catheter having a diameter of about 2.5-French to about 3.5-French. Utilizing two Teflon catheters may provide for low friction sliding of catheter 12 relative to member 14.

In one embodiment, member 14 may accommodate guidewire 15. Guidewire 15 may be fixed relative to member 14 or it may be slidable with relation to member 14. As illustrated, guidewire 15 may extend throughout declotting apparatus 10 and beyond distal portion 24 so that it may, for example, lead declotter 10 into an opening. In one embodiment, guidewire 15 may be constructed from nitinol, stainless steel, or any other suitable material. Although its diameter may vary widely according to application and the inner diameter of member 14, guidewire 15 may have a diameter of about 0.018-inches to about 0.035-inches. The end of guidewire 15, or any portion thereof, may be shaped according to need. With the benefit of this disclosure, those having skill in the art will recognize that any of commercially available guidewires having a suitable size may be used. As illustrated, guidewire 15 may include an

angled tip shown by angled portion 17. In such an embodiment, guidewire 15 having angled tip may be used to effectively guide declotting apparatus within cavities such as vessels or grafts of a patient.

5 In the embodiment of FIG. 4, clips 32 may be configured to secure plurality of deformable members 30. Clips 32 may be coupled to the plurality of deformable members 30 by any means known in the art. In one embodiment, the coupling may include crimping. In other embodiments, welding, gluing, tying, threading, wrapping, or any combination thereof may be used. The size and materials making up clips 32 may vary, but in one embodiment the inventors made be made from stainless steel. Clips 32 may be coupled to catheter 12 and member 14 by any suitable technique known in the art. In one embodiment clip 32 may be coupled to catheter 12 by crimping. In other embodiments, welding, gluing, tying, threading, wrapping, or any combination thereof may be used. Likewise, clip 32 may be coupled to member 14 by crimping, welding, gluing, tying, threading, wrapping, or any combination thereof.

As may be seen in the embodiment of FIG. 4, plurality of deformable members 30 may take on a looped shape exhibited by arrow 33. In other words, at least one of the plurality of deformable members 30 may be shaped so that at least a portion of it may generally loop back on itself. Such a configuration may advantageously allow for a more desirable shape upon being bowed as the distance between proximal portion 22 and distal portion 24 is decreased. The desirable shape may facilitate declotting. Although here shown as having a looped structure, those having skill in the art will recognize that any number of different shapes and configurations may be formed using the plurality of deformable members 30. For instance, deformable members 30 may be designed so that the inventors are arranged in arcuate conformation between pairs of clips 32. In the illustrated embodiment, four deformable members 30 are shown. However, it will be understood that more or fewer deformable members may be used. For instance, it is contemplated that two or more deformable members may be utilized to allow for effective expansion and contraction during operation so that declotting may be performed in accordance with

the present disclosure. Although the size and material may vary widely, in one embodiment, deformable members **30** may be wires, and more particularly, nitinol wires having a diameter of about 0.006-inches to about 0.0011-inches.

5 In one embodiment, plurality of deformable members **30** may be elastically deformable. In such an embodiment, plurality of deformable members **30** may tend to recover their shape in the absence of any applied force (such as the force arising from the sliding of catheter **12** relative to member **14** of FIG. 4). In one embodiment, plurality of deformable members **30** may be programmed to exhibit thermal memory or superelasticity. Programming of superelasticity or thermal memory may be accomplished by any one of a number of techniques known in the art. In one embodiment utilizing nitinol wires having a diameter ranging anywhere from about 0.006 to 0.011 inches, programming may be achieved by first arranging deformable members **30** to form a desired arcuate shape. Having formed the desired shape, deformable members **30** may be secured into place by any suitable means. For instance, in one embodiment, deformable members **30** may be securedly wrapped around a ring of material, such as copper, so that deformable members **30** assume a desired arcuate shape. In another embodiment, a portion of deformable members **30** may be secured about an appropriately shaped material (such as a copper ring surrounding the body of the declotter) by being threaded through one or more holes formed in the material. In one embodiment, deformable members **30** may be threaded through two adjacent holes in a copper ring that surrounds the body of declotting apparatus **10**. Being stretched so as to be threaded through the surrounding ring, deformable members **30** may form an arcuate shape. Being so secured in place, deformable members **30** may be exposed to heat for a certain period of time to complete the programming.

 In one embodiment, heat exposure may be about 500 degrees Celsius, and the exposure time period may be about 5 to about 15 min to achieve superelasticity or about 60 to about 120 min to achieve thermal memory. With programming complete, deformable members **30** may easily be compressed or expanded at room temperature.

With the benefit of the present disclosure, those of skill in the art will understand that different times and temperatures may be used to achieve programming of deformable members 30 . Also, it will be understood that other methods may be used to accomplish superelasticity or thermal memory, and it will also be understood that such programming is optional -- deformable members 30 made of appropriate elastic materials may be adapted to substantially recover an arcuate or other shape upon removal of a force naturally (*i.e.* without any need for heat or other types of programming).

Turning now to FIG. 5, there is shown a declotting apparatus 10 similar in design to the apparatus shown in FIG. 4. In the embodiment of FIG. 5, however, declotting 10 includes a deformable jacket 16 that covers plurality of deformable members 30. Although any suitable material may be used to construct deformable jacket 16, in one embodiment, deformable jacket 16 is constructed from a braided stainless steel mesh. In such an embodiment, small diameter wires (*e.g.*, 0.001-inches to 0.004-inches) may be used to form the mesh. The mesh size may be about 1-mm or less. As was described with reference to FIG. 1, FIG. 2, FIG. 3, deformable jacket 16 may include a lining 17 (FIG. 2) that may prevent the accumulation of material, including clots, within the body of declotting apparatus 10.

In one embodiment, deformable jacket 16 may be made from a thin layer of a stretchable, preferably impermeable material (*e.g.*, polyurethane and the like). In one embodiment, the thickness of such a layer may be about 0.02-mm to about 0.04 mm. The plurality of deformable members 30 may stretch the elastic material to form the desired work-profile of the device. Depending on the degree of expansion of deformable members 30 (that is, on the distance between clips 32) deformable jacket 16 may assume a shape of a flat disc (minimal distance between clips 32) or an elongated fusiform-shape (almost maximum distance between clips 32). Between the two extremes, any intermediate state may be used. In embodiments utilizing an impermeable material, separate lining 17 may be omitted, and material may still be prevented from entering the interior of the device.

Turning now to FIG. 6, there is shown a declotting apparatus **10** including a guidewire **15** extending through distal site **24**. This embodiment demonstrates that the size of guidewire **15** may be varied. In particular, it may be seen that the guidewire **15** of FIG. 6 is substantially larger than the guidewire illustrated in FIG. 4 and FIG. 5. As discussed previously, guidewire **15** may facilitate the maneuvering of declotting apparatus **10** and may be constructed from any suitable material known in the art including, but not limited to, nitinol and stainless steel. In particular, guidewire **15** may be any guidewire commercially available having a size suitable to fit within the working device. Those of skill in the art will recognize that apparatuses shown herein may be produced with or without guidewire compatibility. Accordingly, constructions of devices may vary somewhat from one another.

Turning to FIG. 7 there is shown a declotting apparatus **10** that includes a catheter **12**, a member **14**, a guide **26**, a proximal site **22**, distal site **24**, a plurality of deformable members **30**, a sliding agent **40**, an injection port **50**, and an injector **52**.

The embodiment of FIG. 7 is similar to the embodiments described previously, but in FIG. 7 it is demonstrated that a sliding agent **40** may be designed so as to slide catheter **12** relative to member **14**. In the illustrated embodiment, sliding agent **40** includes hand grip **42**, one-arm lever **44**, spring **46**, and attachment site **48**. In operation, reducing the angle between one-arm lever **44** and hand grip **42** may move catheter **12** relative to member **14**. More specifically, pressing one-arm lever **44** may move catheter **12** distally (*i.e.* towards distal site **24**). Although here illustrated as utilizing a one-arm lever and hand grip, those having skill in the art will understand, with the benefit of the present disclosure, that sliding agent **40** may be configured in any number of suitable alternative manners. For instance, sliding agent **40** may include a single handle coupled to, for instance, catheter **12**. Such a handle may allow for, for example, the direct sliding of catheter **12** relative to member **14**. In one embodiment, one-arm lever **44** or any suitable alternative structure may be

equipped with a lock mechanism that secures any possible position of catheter **12** relative to member **14** continuously without using any determined increments.

5 In one embodiment, spring **46** is a stainless steel spring and is connected to the proximal end of catheter **12**, which may be a 4-F Teflon catheter. Spring **46** may pull the 4-F Teflon catheter back and, as a result of traction, the plurality of deformable members **30**, which may be nitinol wires, may be stretched completely into a fully contracted state. The proximal end of the catheter/ wire system may be equipped with a locking mechanism that keeps the deformable members **30** in a fully contracted state. After unlocking such a mechanism, continuous sliding movement between proximal site **22** and distal site **24** may be carried out by the one -armed lever mechanism illustrated, which may produce the movement of the 4-F Teflon catheter over second member **14**, which may be a nitinol wire or another catheter, such as a Teflon catheter. Releasing lever **44**, spring **46** may retract catheter **12** resulting in a small profile of the plurality of deformable members **30**. It will be understood that although the above embodiment was described with relation to an embodiment utilizing deformable members **30** without a deformable jacket, the description applies equally well for all the other embodiments described herein.

20 In the illustrated embodiment of FIG. 7, injection port **50** may be configured to inject material into or adjacent declotting apparatus **10** during its manipulation within, for instance, a vessel. In the illustrated embodiment, injection port **50** includes a side arm coupled to the shaft of declotting apparatus **10**. More particularly, in the embodiment of FIG. 7, injection port **50** may be coupled to catheter **12**. In operation, a material may be introduced into injection port **50**, and that material may travel within a lumen defined by catheter **12** and leading toward a plurality of deformable members **30** of declotting apparatus **10**. The material introduced to injection port **50** may exit declotting apparatus **10** through a suitable injector. In the embodiment of FIG. 7, injector **52** may be configured to release material introduced *via* injection port **50** and traveling within catheter **12**.

In FIG. 7, injector 52 may be an opening formed in, for instance, catheter 12. However, it will be understood that many different suitable designs may be substituted with the one shown for injector 52. For instance, one or more openings may be situated about catheter 12 or member 14 so that material introduced into injection port 50 or female Luer adapter (see element 60, FIG. 8) may be released from declotting apparatus 10 in one more different release patterns. In one embodiment, one to six side holes may be located close to the distal tip of catheter 12. In one embodiment, injector 52 may be configured to spray a material adjacent declotting apparatus 10. Injection port 50 and injector 52 may be utilized, in one embodiment, to inject contrast near declotting apparatus 10. In other embodiments, injection port 50 and injector 52 may be utilized to inject heparin and/or urokinase solution directly into a target area so that thrombolysis may be promoted. With the benefit of the present disclosure those having skill in the art will recognize that any number of other materials may be injected from declotting apparatus 10 to perform any number of varying applications.

Turning to FIG. 8, there is shown another embodiment utilizing an injection port 50. There, it may be seen that a female Luer adapter 60 may be coupled to member 14 (provided that member 14 defines a lumen). In this embodiment, Luer attachment 60 may serve at least two goals: it may accept a guidewire, and it allows some fluid to be injected through a lumen of member 14. In one embodiment, member 14 may be equipped with multiple side holes between proximal site 22 and distal site 24 (see, *e.g.*, FIG. 7) provided that deformable jacket 16 is not equipped with lining 17. If lining 17 is coupled to deformable jacket 16 or deformable members 30, side holes may be created outside the distal portion of 14 covered by such a lining 17. For example, holes may be positioned, in one embodiment, between distal site 24 and guide 26 or close to the distal tip of catheter 12. The Luer attachment site 60 may enable one, in one embodiment, to attach a check-flow adapter with a check-flow valve and a side arm; using this assembly, some fluid (contrast, heparin, urokinase, or the like) may be injected even if a guidewire is positioned within a lumen defined by member 14.

In the embodiment of FIG. 7, it may be seen that there may be one more than one proximal sites **22**. Such an embodiment demonstrates that different deformable members **30** may be coupled to catheter **12** at different locations along catheter **12**.
5 Being coupled at different locations, plurality of deformable members **30** may be made to define different shapes. For instance, in the illustrated embodiments, it may be seen that deformable members **30** may define a shape having a wider upper portion and a thinner lower portion. More specifically, in the illustrated embodiment, the deformable member **30** that is coupled at a higher location along catheter **12** assumes
10 a wider shape than deformable member **30** that have a lower proximal site. Although not so illustrated, it is contemplated that coupling sites along member **14** may be spaced so that a desired shape of declotting apparatus **10** may be achieved. For instance, each of the plurality of deformable members **30** may be coupled to member **14** at slightly different distal sites **24** so that a unique shape may be formed.

15
Turning to FIG. 9A and FIG. 9B, there are shown other embodiments for a sliding agent **40**. In these embodiment, spring **68** may be configured to pull the proximal end of catheter **12** to stretch/elongate the working profile of declotter **10**. The declotter may be expanded, or "activated", by pushing thumb-button **64** coupled
20 to grip body **62** and to the outer surface of catheter **12** distally. As a result, the working profile of declotter **10** may increase in diameter. In one embodiment, thumb-button **64** may be fixed at certain points by ratchet mechanism **66**. In particular, portion **67** may engage ratchet mechanism **66** so as to lock thumb button **64**, and consequently the diameter of declotter **10**, in place. In one embodiment, such a
25 locking may be accomplished by pushing thumb-button **64** distally and then laterally to fix it in position within ratchet mechanism **66**. Using such an embodiment, one may achieve a series of controllable, different sizes of the working profile of declotter **10**. More specifically, deformable jacket **16**, of for instance, FIG. 1, or plurality of deformable members **30** of, for instance, FIG. 4 may be fixed in place so that a
30 desirable diameter may be easily maintained.

Turning to FIG. 10, there is shown a declotting apparatus **10** being used for the recanalization of a hemodialysis PTFE graft **55**. As illustrated, declotting apparatus **10** may be utilized as a recanalization of both venous and arterial limbs of the hemodialysis graft **55**. Treatment with declotting apparatus **10** may be performed subsequent to balloon angioplasty of all possible stenoses. In one embodiment, recanalization of the venous limb may be achieved by using declotting apparatus **10** to dislodge one or more soft clots of the venous limb of graft **55**. Declotting apparatus **10** may be moved back and forth while continuously changing the diameter of a deformable jacket or of a plurality of deformable members as described herein. Clots may be aspirated (Bethard, 1996) or pushed toward central veins (Trerotola, 1994; Middlebrook, 1995). By using declotting apparatus **10** with a changing diameter, intragraft stenoses may be macerated and dislodged.

In case of intragraft stenosis, one may dilate the graft itself to macerate clots further (Beathard, 1996). In these cases, the declotting apparatus **10** offers a combined approach: using the apparatus with a changing diameter, taking advantage of the strong and continuously controllable wall contact between the device and the graft wall, plus utilizing the dilation capacity of the device, the intragraft stenosis(es) can be macerated and dislodged. After balloon dilation, thrombi may remain in place partially compressed to the wall of the graft and may induce a new thrombotic process. For removal of the arterial plug, the declotting apparatus **10** may be passed across the arterial anastomosis in its completely stretched profile (*i.e.* in a contracted state). The deformable jacket or plurality of deformable members may then be expanded so that the apparatus assumes the diameter of the parent artery and is gently pulled back to the tip of the insertion sheath located in the venous limb of the graft. In this case, the device may be used in a manner similar to a Fogarty embolectomy catheter.

In one embodiment, treatment of a thrombosed hemodialysis access graft may include two parts: restore the flow in the venous side eliminating the stenosis(es) and restore the flow within the graft. The stenosis at the venous anastomosis (together

with possible more proximal stenoses located in the central veins) may be treated first with angioplasty. To eliminate the venous stenosis the embodiment that uses a braided stainless steel mesh as deformable jacket **16** may be used. In this application, the device may be used to exert lateral forces to the lesion, eliminating the need for
5 using a dilatation balloon catheter for this purpose. The second step may be clot maceration in the graft (especially in the venous limb), as well as the removal of intragraft thromboses and the arterial plug. In the embodiments described herein, it will be understood that the same declotting apparatus **10** may be utilized for recanalization of both the venous and the arterial limbs of the hemodialysis graft.
10 Additionally, it will be understood that an access sheath may be used for insertion in all of these embodiments. In particular, declotting apparatus **10** may take on a contracted state (and, as described in relation to FIG. 7, may be locked in such a state) so that the apparatus may be inserted into an access sheath or guide, such as a guiding catheter.

15

Although FIG. 10 illustrates the recanalization of an access graft **55**, those having skill in the art will understand that the applications for declotting apparatus **10** are indeed vast. For example, the design may also be used in all applications where other designs, including, but not limited to, designs mentioned in the Description of
20 Related Art section of this disclosure. For instance, one possible application may be to remove thrombus/embolus from native arteries or from PTFE or other synthetic arterial grafts (replacing the widely used Fogarty Embolectomy Catheter , Fogarty Adherent Clot Catheter or Fogarty Graft Thrombectomy Catheter (all from Baxter). Clots developing in synthetic graft materials may be highly organized, more mature,
25 and adherent. Their removal may require stronger devices because balloons tend to rupture. Utilizing the radial force exerted by the device as disclosed herein, the presently described apparatus may be used instead of a dilatation balloon catheter to treat short stenoses within the vasculature. The continuously changeable working profile of the disclosed apparatus along with its expansile force (in particular,
30 embodiments utilizing a braided mesh design) may enable one to recanalize long segments of diseased arteries or veins.

In general, the disclosed method and apparatus may be used for, but is not limited to declotting a thrombosed hemodialysis a-v graft, clot maceration (instead of occlusion-type balloon catheters or angioplasty), removal of arterial plug (instead of a Fogarty balloon catheter or a Fogarty Adherent Clot Catheter), elimination of intragraft thrombosis(es) (instead of angioplasty balloon catheters or Fogarty Adherent Clot Catheters), and angioplasty of the venous stenosis (instead of angioplasty balloon catheters).

For angioplasty of the venous stenosis, one embodiment for declotting may include, but is not limited to the following steps. The stenosis at the venous anastomosis may be treated first using a presently disclosed declotter 10 in a manner similar to an angioplasty device. Clot maceration may be done using the device in a manner similar to an occlusion-balloon/ or PTA balloon. Elimination of intragraft thromboses may be accomplished using the device in a manner similar to an angioplasty device. Removal of the arterial plug may be accomplished using the device in a manner similar to a Fogarty embolectomy balloon or device.

In one embodiment, a declotter 10 may be produced in a length (*e.g.*, about 60 cm to about 100 cm) that allows for using the design for embolectomy/thrombectomy/angioplasty in locations other than the a-v graft. In one embodiment, emboli may be removed from the peripheral arteries or pulmonary arteries. During such a procedure, the declotter may be advanced over a guidewire behind the embolus, then the working profile may be activated. The profile, which in one embodiment may include a braided mesh deformable jacket, may then be pulled back and out from the body together with the entrapped embolus.

A further application may be to use a disclosed device for recanalization of lengthy arterial or venous stenoses or occlusions. In such an application, a device may travel over a guidewire that has been advanced through the seriously stenosed and/or completely occluded segment of the vessel. The recanalization may consist of

a series of repeated movements such as (a) working profile activation, (b) profile deactivation (relaxation), profile advancement, profile activation, profile relaxation, and so forth, until the afflicted lumen becomes patent.

5 In such an application, the device may be used over a guidewire that has been negotiated through the stenosed and/or occluded segment of the vessel. The device may be moved distally in a determined length (determined, for instance, by the length of deformable jacket 16) guided by the guidewire. The work-profile of the device may be "activated". The compressible material (such as atherosclerotic mass and/or
10 thrombus) may be pressed onto the internal layer of the vessel and/or between the layers of the vessel. This mechanism is well known in the art as the technique of angioplasty. The treated segment's lumen may increase in size. The device may then be moved distally in another determined length and the procedure may be repeated. After a series of dilations, the lumen of the afflicted vessel may be rendered widely
15 patent. The procedure may be repeated during withdrawal of the device all along proximally. The procedure may be facilitated by injecting contrast, heparin, or urokinase for quickness and safety. This procedure (recanalization) may be followed by placement of a stent or stents to maintain the achieved patency.

20 While the present disclosure may be adaptable to various modifications and alternative forms, specific embodiments have been shown by way of example and described herein. However, it should be understood that the present disclosure is not intended to be limited to the particular forms disclosed. Rather, it is to cover all modifications, equivalents, and alternatives falling within the spirit and scope of the
25 disclosure as defined by the appended claims. For instance, the disclosed apparatus may utilize different orientations of components, sizes of components, or materials according to needs. Moreover, the different aspects of the disclosed methods and apparatuses may be utilized in various combinations and/or independently. Thus the invention is not limited to only those combinations shown herein, but rather may
30 include other combinations. In other words, those of skill in the art should, in light of the present disclosure, appreciate that many changes can be made in the specific

embodiments that are disclosed and still obtain a like or similar result without departing from the spirit and scope of the invention.

References

The following references, to the extent that they provide exemplary procedural or other details supplementary to those set forth herein, are specifically incorporated
5 herein by reference.

U.S. Patent No. 4,921,484

Beathard, "Mechanical versus pharmacomechanical thrombolysis for the treatment of thrombosed dialysis access grafts," *Kidney Int.*, 45:1401-1406, 1994.

10 Bethard, Welch, Maidment, "Mechanical thrombolysis for the treatment of thrombosed hemodialysis access grafts," *Radiology*, 200:711-716, 1996.

Feldman, Held, Hutchinson *et al.*, "Vascular access morbidity in the US," *Kidney Int.*, 43:1091-1096, 1993.

15 Gray, "Percutaneous intervention for permanent hemodialysis access: A review," *JVIR*, 8:313-327, 1997.

Kinney, Valji, Rose, Yeung, Oglevie, Roberts *et al.*, "Pulmonary emboli occurring with pulse-spray pharmacomechanical thrombolysis of clotted dialysis grafts with urokinase or heparinized saline," Abstract No. 169, p 272, 24th Annual Scientific Meeting of SCVIR, Orlando, FL, March 20-25, 1999.

20 Kumpe, "Fibrinolysis and angioplasty in the treatment of failed dialysis access sites," *In: JVIR Supplement*, Scientific Program of SCVIR 22nd Annual Scientific Meeting, Washington, D.C., pp 120-126, March 8-13, 1997.

25 Mailloux, Bellucci, Napolitano, Mossey, Wilkes, Bluestone, "Survival estimates for 683 patients starting dialysis from 1970 through 1989: Identification of risk factors for survival," *Clin. Nephrol.*, 42:1127-135, 1994.

Middlebrook, Amygdalos, Soulen, Haskal, Shlansky-Goldberg, Cope, Pentecost, "Thrombosed hemodialysis grafts: percutaneous mechanical balloon declotting versus thrombolysis," *Radiology*, 196:73-77, 1995.

30 "Modified use of the Arrow-Trerotola percutaneous thrombolytic device for treatment of thrombosed dialysis graft," Abstract No. 71, p 233, 24th Annual Scientific Meeting of SCVIR, Orlando, FL, March 20-25, 1999.

- Trerotola, "Mechanical thrombolysis of hemodialysis grafts," *In: JVIR Supplement*, Scientific Program of SCVIR 22nd Annual Scientific Meeting, Washington, D.C., pp 126-130, March 8-13, 1997.
- 5 Trerotola, Harris, Snidow, Johnson, "Technical note: percutaneous use of the Fogarty adherent clot catheter," *JVIR*, 6:578-580, 1995.
- Trerotola, Lund, Scheel, Savader, Venbrux, Osterman, "Thrombosed hemodialysis access grafts: percutaneous mechanical declotting without urokinase," *Radiology*, 191:721-726, 1994.
- 10 Uflacker, Rajagopalan, Vujic, Stutley, "Treatment of thrombosed dialysis access grafts: Randomized trial of surgical thrombectomy versus mechanical thrombectomy with the Amplatz device," *JVIR*, 7:185-192, 1996.
- Vorwerk, Sohn, Schurmann, Hoogeveen, Gladziwa, Guenther, "Hydrodynamic thrombectomy of hemodialysis fistulas: First clinical results," *JVIR*, 5:813-821, 1994.

CLAIMS:

1. A declotting apparatus comprising:
 - a catheter;
 - 5 a member positioned within said catheter, said member slidable relative to said catheter;
 - a plurality of deformable members forming at least one loop, said members having a proximal portion and a distal portion, said proximal portion being coupled to said catheter at a proximal site and said distal portion
10 being coupled to said member at a distal site;
 - wherein said proximal site and said distal site are separated by a distance;
 - wherein said plurality of deformable members are configured to bow as said catheter slides to reduce said distance; and
 - wherein said plurality of deformable members are configured to compress as
15 said catheter slides to increase said distance.
2. The apparatus of claim 1, wherein said plurality of deformable members form at least two loops.
- 20 3. The apparatus of claim 1, wherein said plurality of deformable members are programmed with thermal memory.
4. The apparatus of claim 1, wherein said plurality of deformable members are programmed with superelasticity.
25
5. The apparatus of claim 1, wherein said plurality of deformable members comprise nitinol wire.
6. The apparatus of claim 1, wherein said plurality of deformable members are
30 elastically deformable.

7. The apparatus of claim 1, further comprising a deformable jacket in operable relation to said plurality of deformable members and configured to cover at least a portion of said plurality of deformable members.
- 5 8. The apparatus of claim 7, wherein said deformable jacket is configured to expand as said plurality of deformable members bow and wherein said deformable jacket is configured to contract as said plurality of deformable members compress.
9. The apparatus of claim 7, wherein said deformable jacket comprises braided
10 stainless steel mesh.
10. The apparatus of claim 7, further comprising a liner coupled to an inner surface of said deformable jacket and configured to prevent material from entering an interior of said apparatus.
- 15 11. The apparatus of claim 1, further comprising a pair of clips coupled to said plurality of deformable members.
12. The apparatus of claim 1, further comprising a sliding agent in operative relation
20 to said catheter and said member and operable to slide said catheter relative to said member.
13. The apparatus of claim 12, wherein said sliding agent comprises:
a hand grip;
25 a one-arm lever coupled to said hand grip and to said catheter;
a luer adaptor coupled to said member; and
a spring coupled to said hand grip and to said one-arm lever, said spring
extending therebetween.
- 30 14. The apparatus of claim 12, wherein said sliding agent comprises:
a grip body;

- a luer adaptor coupled to said grip body;
a spring coupled to said grip body and configured to pull said catheter to
compress said deformable members;
a thumb button coupled to said spring and said catheter and configured to
5 control the extent of compression of said deformable members; and
a ratchet mechanism in operative relation to said thumb button and configured
to engage said thumb button to lock a position of said deformable
members.
- 10 15. The apparatus of claim 1, further comprising a lock in operative relation to said
catheter and said member and configured to fix the distance between said proximal
site and said distal site.
- 15 16. The apparatus of claim 1, further comprising an injection port and one or more
injectors coupled to said catheter.
17. The apparatus of claim 1, wherein said member comprises a catheter.
18. The apparatus of claim 17, further comprising a guidewire positioned within said
20 catheter and extending through said distal site.
19. The apparatus of claim 18, wherein said guidewire is angled.
20. The apparatus of claim 1, wherein said member comprises a nitinol microtubing.
- 25 21. The apparatus of claim 1, wherein said member comprises a nitinol wire.
22. A clotting apparatus comprising:
a first catheter defining a first lumen;

- a second catheter defining a second lumen, said second catheter positioned within said first lumen, said second catheter slidable relative to said first catheter;
- 5 a deformable jacket having a proximal end and distal end, said proximal end being coupled to said first catheter at a proximal site and said distal end being coupled to said second catheter at a distal site;
- a guidewire positioned within said second catheter and extending through said distal site;
- 10 a liner coupled to an inner surface of said deformable jacket and configured to prevent material from entering an interior of said apparatus;
- wherein said proximal site and said distal site are separated by a distance;
- wherein said deformable jacket is configured to expand as said first catheter slides to reduce said distance; and
- 15 wherein said deformable jacket is configured to contract as said first catheter slides to increase said distance.
23. The apparatus of claim 22, further comprising a plurality of deformable members coupled between said proximal site and said distal site.
- 20 24. The apparatus of claim 23, wherein said plurality of deformable members form at least one loop.
- 25 25. The apparatus of claim 23, wherein said plurality of deformable members are programmed with thermal memory.
26. The apparatus of claim 23, wherein said plurality of deformable members are programmed with superelasticity.
- 30 27. The apparatus of claim 23, wherein said plurality of deformable members comprise nitinol wire.

28. The apparatus of claim 23, further comprising a pair of clips coupled to said plurality of deformable members.
29. The apparatus of claim 22, wherein said deformable jacket comprises braided stainless steel mesh.
30. The apparatus of claim 22, further comprising a lock in operative relation to said first and second catheters and configured to fix the distance between said proximal site and said distal site.
31. The apparatus of claim 22, further comprising a sliding agent in operative relation to said first and second catheters and operable to slide said first catheter relative to said second catheter.
32. The apparatus of claim 22, further comprising an injection port and one or more injectors coupled to said first catheter.
33. The apparatus of claim 22, wherein said second catheter comprises a nitinol microtubing.
34. A method for declotting a site, comprising:
providing a declotter including: a catheter; a member positioned within said catheter; a plurality of deformable members forming at least one loop, said members having a proximal portion and a distal portion, said proximal portion being coupled to said catheter at a proximal site and said distal portion being coupled to said member at a distal site; said proximal site and said distal site being separated by a distance; and a deformable jacket in operable relation to said plurality of deformable members;

compressing said plurality of deformable members by sliding said catheter relative to said member to increase said distance and to contract said deformable jacket;

positioning said declotter adjacent said site; and

5 bowing said plurality of deformable members by sliding said catheter relative to said member to decrease said distance and to expand said deformable jacket to declot said site.

10 35. The method of claim 34, further comprising locking said deformable jacket in a contracted state.

36. The method of claim 34, further comprising continuously modifying a diameter of said deformable jacket by sliding said catheter relative to said member.

15 37. The method of claim 34, wherein said declotter further comprises an injection port and one or more injectors coupled to said catheter, and wherein said method further comprises injecting contrast through said declotter with said injection port

20 38. The method of claim 34, wherein said site is an thrombosed hemodialysis access graft site.

39. The method of claim 34, wherein said site is a thrombosed intragraft site.

25 40. The method of claim 34, wherein said site is a venous stenosis site.

41. A method for declotting a site, comprising:

providing a declotter including: a first catheter defining a first lumen; a second catheter defining a second lumen, said second catheter positioned within said first lumen; a guidewire positioned within said second catheter; a deformable jacket having a proximal end and distal end, said proximal end being coupled to said first catheter at a proximal site

30

and said distal end being coupled to said second catheter at a distal site;
wherein said proximal site and said distal site are separated by a
distance; and a liner coupled to an inner surface of said deformable
jacket;

5 contracting said deformable jacket by sliding said first catheter relative to said
 second catheter to increase said distance;
 maneuvering said declotter with said guidewire;
 positioning said declotter adjacent said site; and
 expanding said deformable jacket by sliding said first catheter relative to said
10 second catheter to decrease said distance to declot said site.

42. The method of claim 41, further comprising preventing material from entering an
interior of said declotter with said liner.

15 43. The method of claim 41, further comprising continuously modifying a diameter
of said deformable jacket by sliding said first catheter relative to said second catheter.

44. The method of claim 41, wherein said site is an thrombosed hemodialysis access
graft site.

20

45. The method of claim 41, wherein said site is a thrombosed intragraft site.

46. The method of claim 41, wherein said site is a venous stenosis site.

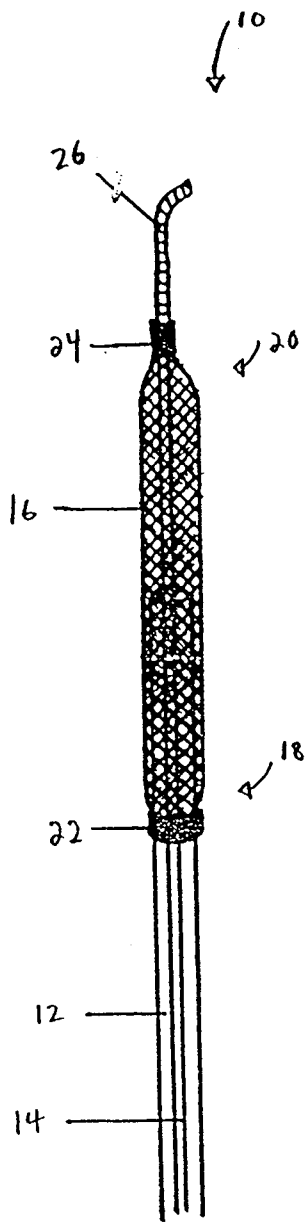

FIG. 1

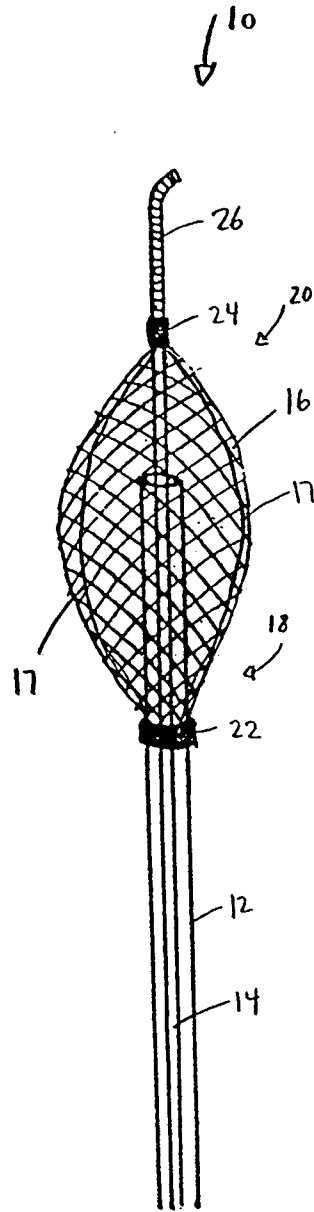

FIG. 2

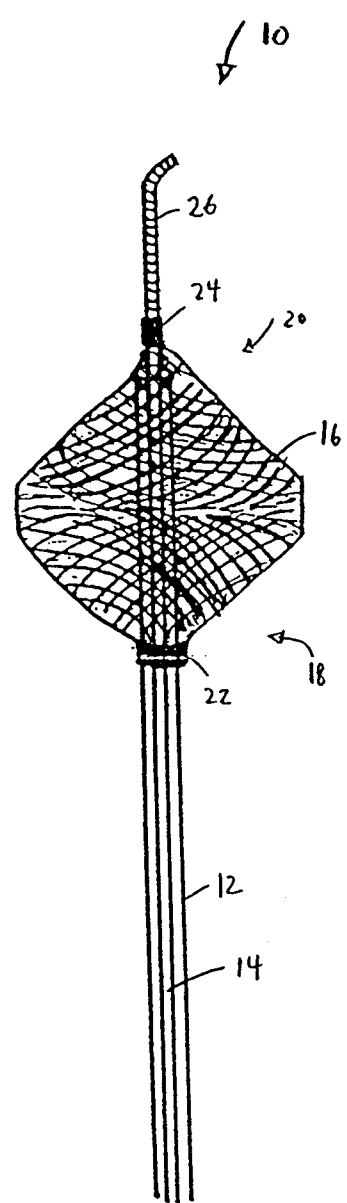

FIG. 3

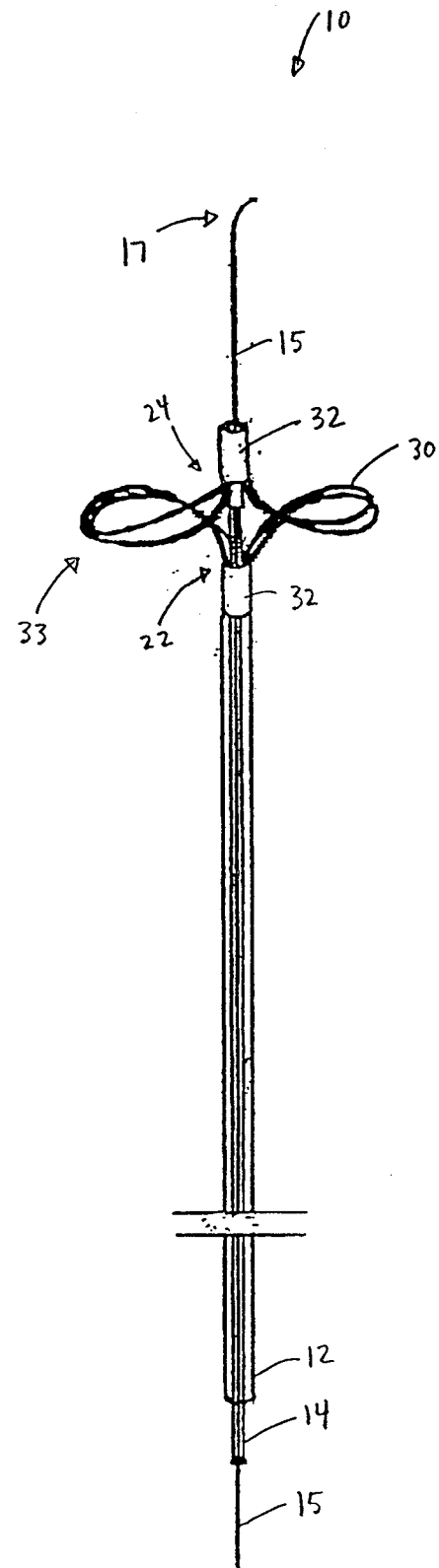

FIG. 4

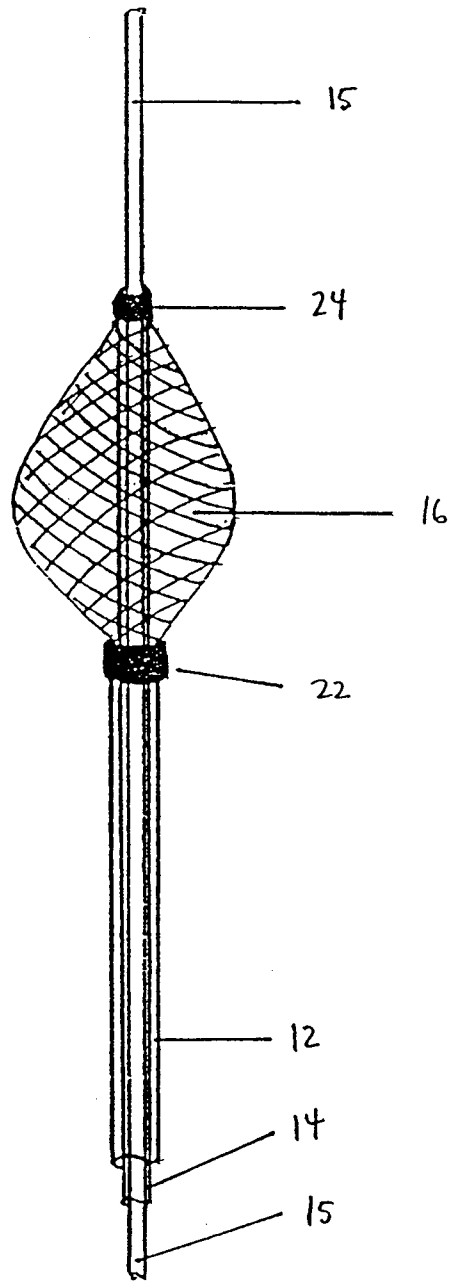

FIG. 6

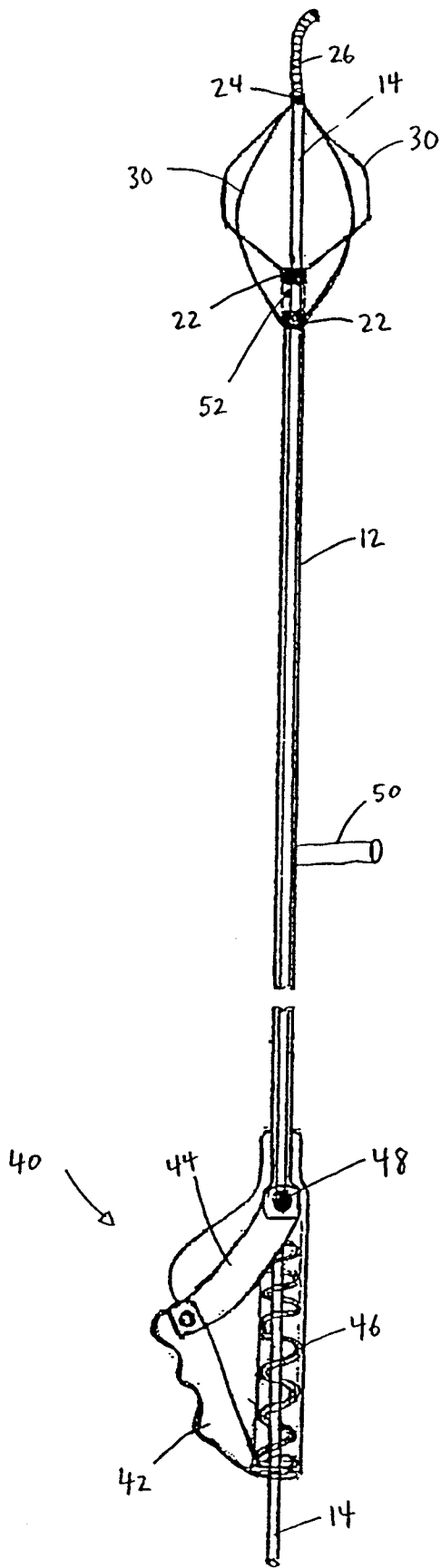

FIG. 7

6/8

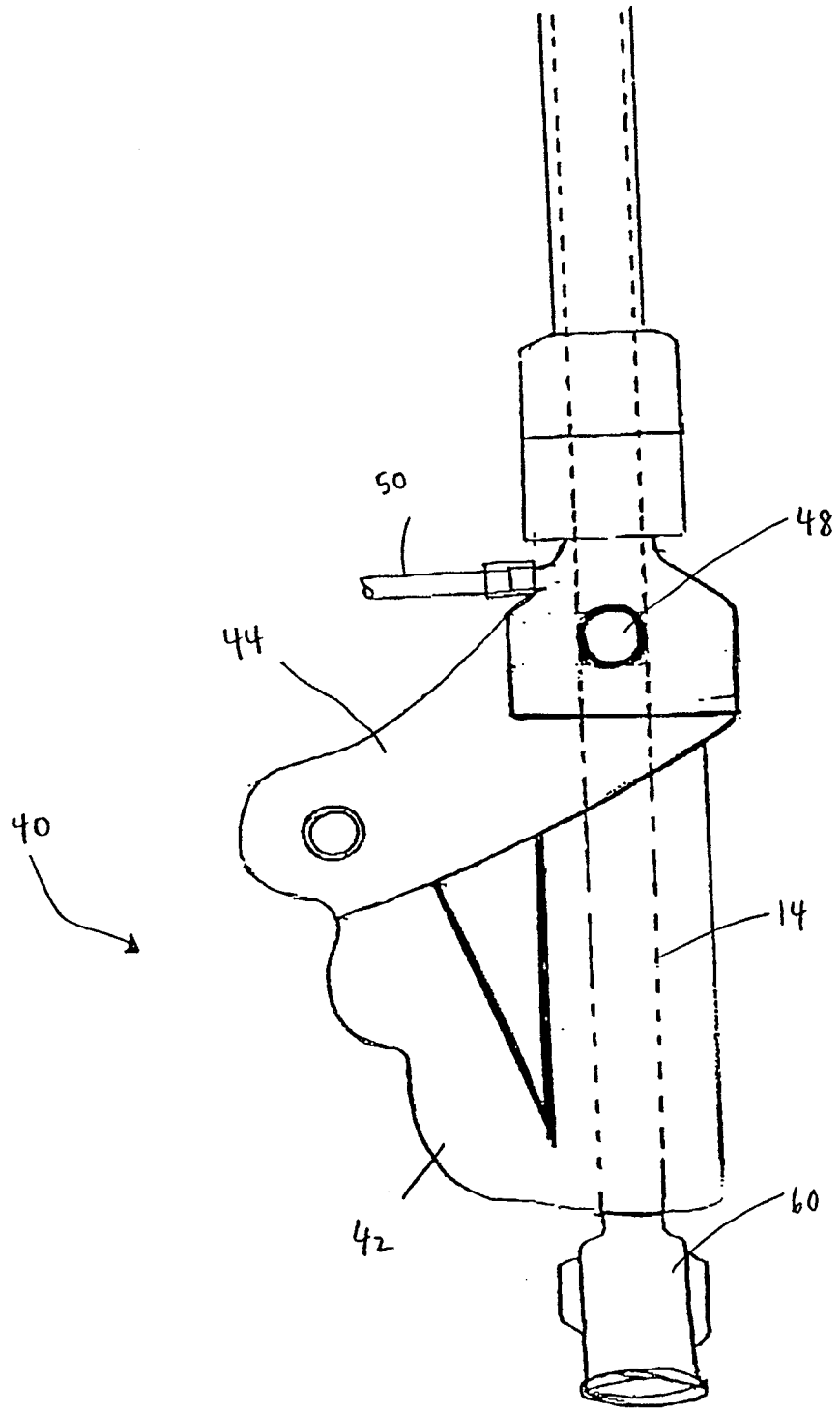

FIG. 8

7/8

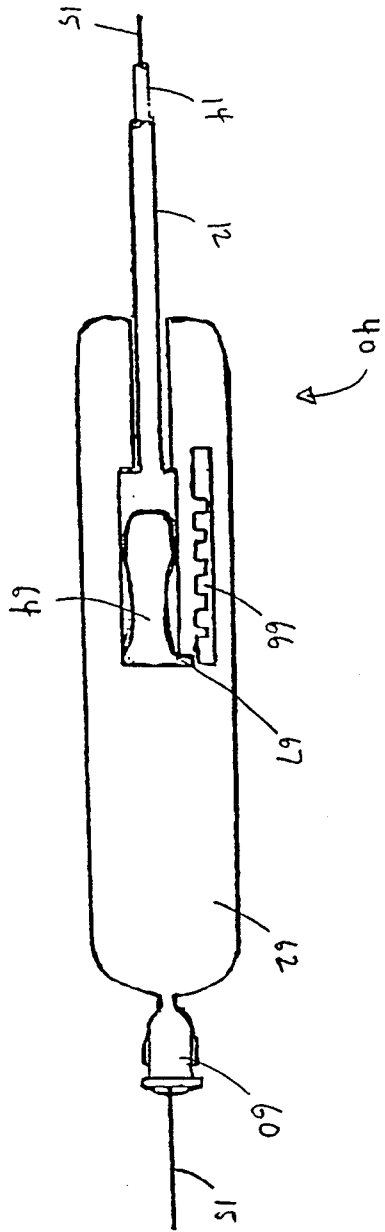

FIG. 9B

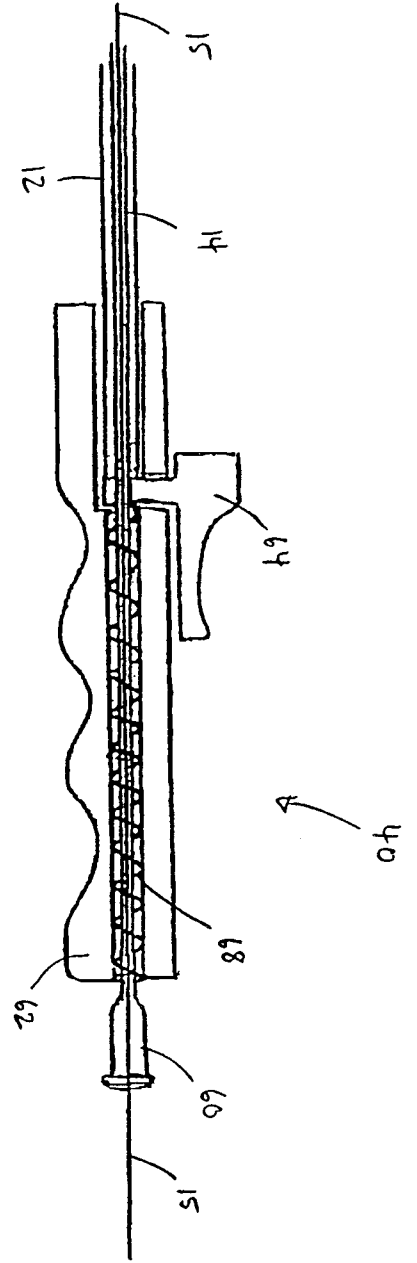
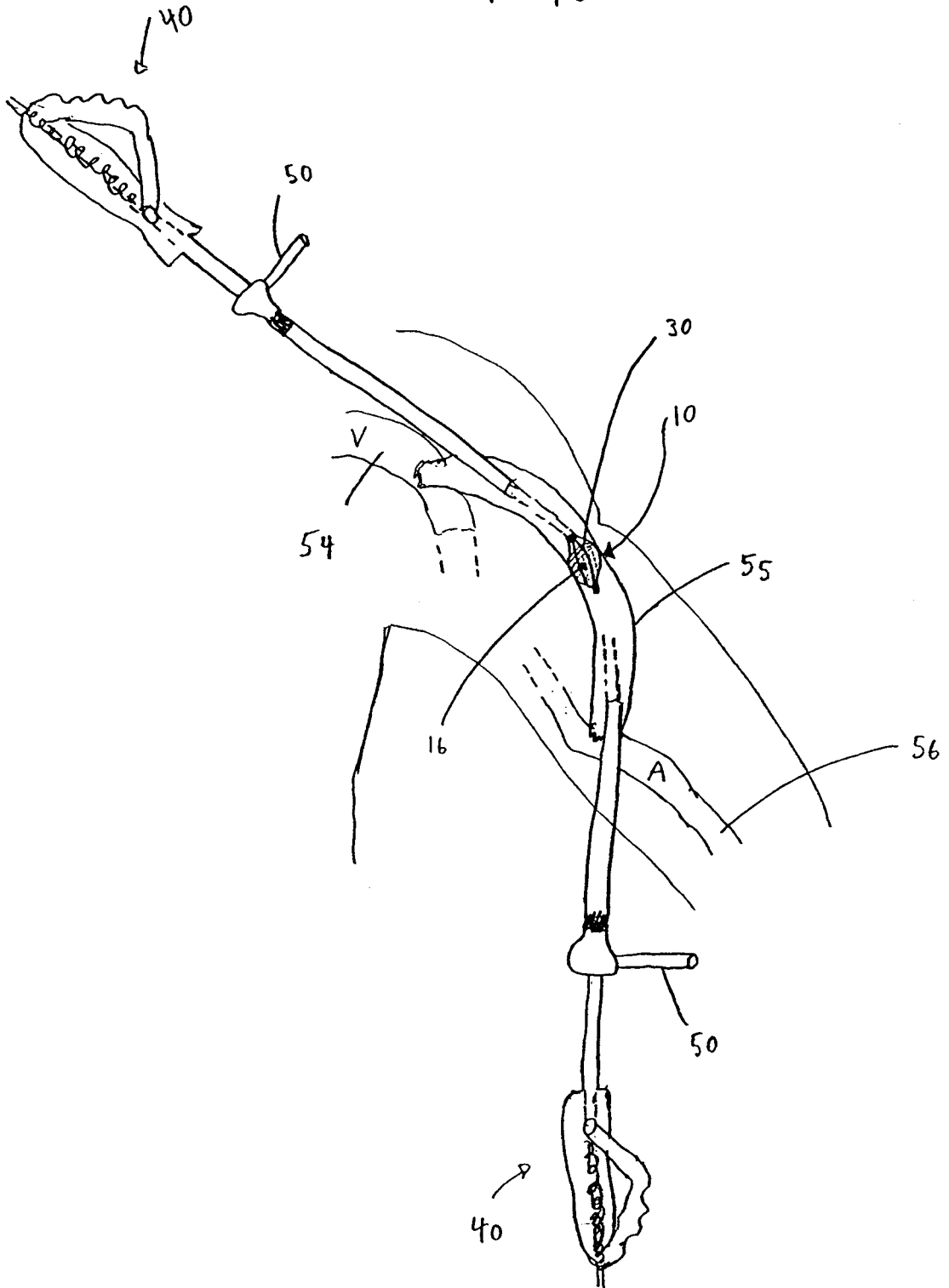

FIG. 9A

FIG. 10



INTERNATIONAL SEARCH REPORT

International Application No

PCT/US 00/05441

A. CLASSIFICATION OF SUBJECT MATTER

IPC 7 A61B17/22

According to International Patent Classification (IPC) or to both national classification and IPC

B. FIELDS SEARCHED

Minimum documentation searched (classification system followed by classification symbols)

IPC 7 A61M A61F A61B

Documentation searched other than minimum documentation to the extent that such documents are included in the fields searched

Electronic data base consulted during the international search (name of data base and, where practical, search terms used)

EPO-Internal, WPI Data

C. DOCUMENTS CONSIDERED TO BE RELEVANT

Category °	Citation of document, with indication, where appropriate, of the relevant passages	Relevant to claim No.
A	US 5 540 707 A (KUGLER ET AL.) 30 July 1996 (1996-07-30) abstract column 2, line 50 - line 55 column 3, line 56 - column 4, line 2 column 6, line 29 - line 38 column 7, line 1 - line 5 column 7, line 29 - line 40 column 12, line 64 - column 13, line 5; figures 1,4,5,12-14,21 --- -/--	1-15, 18-31, 33

Further documents are listed in the continuation of box C.

Patent family members are listed in annex.

° Special categories of cited documents :

- *A* document defining the general state of the art which is not considered to be of particular relevance
- *E* earlier document but published on or after the international filing date
- *L* document which may throw doubts on priority claim(s) or which is cited to establish the publication date of another citation or other special reason (as specified)
- *O* document referring to an oral disclosure, use, exhibition or other means
- *P* document published prior to the international filing date but later than the priority date claimed

- *T* later document published after the international filing date or priority date and not in conflict with the application but cited to understand the principle or theory underlying the invention
- *X* document of particular relevance; the claimed invention cannot be considered novel or cannot be considered to involve an inventive step when the document is taken alone
- *Y* document of particular relevance; the claimed invention cannot be considered to involve an inventive step when the document is combined with one or more other such documents, such combination being obvious to a person skilled in the art.
- *&* document member of the same patent family

Date of the actual completion of the international search

21 June 2000

Date of mailing of the international search report

28/06/2000

Name and mailing address of the ISA

European Patent Office, P.B. 5818 Patentlaan 2
 NL - 2280 HV Rijswijk
 Tel. (+31-70) 340-2040, Tx. 31 651 epo nl,
 Fax: (+31-70) 340-3016

Authorized officer

Michels, N

INTERNATIONAL SEARCH REPORT

International Application No

PCT/US 00/05441

C.(Continuation) DOCUMENTS CONSIDERED TO BE RELEVANT

Category °	Citation of document, with indication, where appropriate, of the relevant passages	Relevant to claim No.
A	<p>FR 2 652 267 A (PROTHIA S.A.R.L.) 29 March 1991 (1991-03-29)</p> <p>abstract page 5, line 7 - line 17 page 9, line 1 - line 19; figures 2,3,8</p>	<p>1,2,11, 12,16, 17, 22-24, 30-32</p>
A	<p>WO 98 25656 A (MEDTRONIC, INC.) 18 June 1998 (1998-06-18)</p> <p>abstract page 5, line 35 -page 6, line 33 page 12, line 35 -page 13, line 13; figures 3,4A-E</p>	<p>1,3-6, 22,23, 25-28</p>
A	<p>US 4 619 246 A (MOLGAARD-NIELSEN ET AL.) 28 October 1986 (1986-10-28)</p> <p>abstract; figures 1-3</p>	<p>1,2, 7-10,22, 29</p>
A	<p>US 5 788 710 A (BATES ET AL.) 4 August 1998 (1998-08-04)</p> <p>abstract; figures 2,2A-C</p>	<p>1,12-14</p>
A	<p>US 5 329 942 A (GUNTHER ET AL.) 19 July 1994 (1994-07-19)</p>	

INTERNATIONAL SEARCH REPORT

Information on patent family members

International Application No

PCT/US 00/05441

Patent document cited in search report	Publication date	Patent family member(s)	Publication date
US 5540707 A	30-07-1996	US 5490859 A	13-02-1996
		US 5836868 A	17-11-1998
		US 5792157 A	11-08-1998
		US 5897567 A	27-04-1999
		CA 2161640 A	10-11-1994
		EP 0794734 A	17-09-1997
		JP 8509639 T	15-10-1996
		WO 9424946 A	10-11-1994
		US 5501694 A	26-03-1996
		CA 2149014 A	26-05-1994
		EP 0719111 A	03-07-1996
		JP 8503154 T	09-04-1996
		WO 9410919 A	26-05-1994
FR 2652267 A	29-03-1991	NONE	
WO 9825656 A	18-06-1998	EP 0968015 A	05-01-2000
US 4619246 A	28-10-1986	DK 252984 A	24-11-1985
		AT 54812 T	15-08-1990
		AU 577377 B	22-09-1988
		AU 4273885 A	28-11-1985
		CA 1241581 A	06-09-1988
		DE 3578831 D	30-08-1990
		EP 0165713 A	27-12-1985
		JP 1840108 C	25-04-1994
		JP 5054344 B	12-08-1993
		JP 61041444 A	27-02-1986
US 5788710 A	04-08-1998	US 5957932 A	28-09-1999
US 5329942 A	19-07-1994	AU 643816 B	25-11-1993
		AU 8240591 A	20-02-1992
		CA 2048307 A,C	15-02-1992
		EP 0472334 A	26-02-1992
		JP 2714501 B	16-02-1998
		JP 5076535 A	30-03-1993